

PHILIPS
VARI***LITE**



VL4000 BeamWash Luminaire User's Manual

All other brand or product names which may be mentioned in this manual are trademarks or registered trademarks of their respective companies or organizations.

Vari-Lite reserves the right to change details of design, materials and finishes. Information, graphics, drawings, specifications, etc. are subject to change without notice. Some features may be the result of future software updates. VARI***LITE** automated lighting equipment is made in the U.S.A.

Please check www.vari-lite.com for latest version. Vari-Lite assumes no responsibility or liability for any errors or inaccuracies that may appear in this manual. All information and graphics are property of Vari-Lite, 10911 Petal Street Dallas, Texas 75238 USA.

Version as of: **13 February 2018**

Part number: **02.9704.6002 A**

VL4000 BeamWash Luminaire User's Manual
©2014 - 2018 Vari-Lite company. All Rights Reserved.

How To Obtain Warranty Service

A copy of the Vari-Lite Limited Warranty was included in the shipping package for this VARI*LITE product.

To obtain warranty service, please contact customer service at 1-877-VARI-LITE (1-877-827-4548), +1-214-647-7880, or entertainment.service@philips.com and request a Return Material Authorization (RMA) for warranty service. You will need to provide the model and serial number of the item being returned, a description of the problem or failure and the name of the registered user or organization. If available, you should have your sales invoice to establish the date of sale as the beginning of the warranty period.

Once you obtain the RMA, pack the unit in a secure shipping container or in its original packing box. Go to the Vari-Lite web site www.vari-lite.com, click on the Support link, and download the RMA form. Put the completed RMA form in shipping container along with a copy of your invoice (if available). Write the RMA number legibly on or near the shipping address label and return the unit, freight prepaid to:

Vari-Lite
Attention: Warranty Service (RMA# _____)
10911 Petal Street
Dallas, Texas 75238 USA

As stated in the warranty, it is required that the shipment be insured and FOB our service center.

Compliance Notice

FCC This equipment has been tested and found to comply with the limits for a Class A digital device pursuant to Part 15 of FCC Rules. These limits are designed to provide reasonable protection against harmful interference when this equipment is operated in a commercial environment. This equipment generates, uses, and can radiate radio frequency energy and, if not installed and used in accordance with Vari-Lite system, service, and safety guidelines, may cause harmful interference to radio communications.

As tested under this standard:

FCC 47CFR 15B cIA*CEI

Issued:2009/10/01 Title 47 CFR Part 15 Subpart B Unintentional Radiators Class A

Operation of this equipment in a residential area is likely to cause harmful interference, in which case the user will be required to correct the interference at his/her own expense.



EC Declaration of Conformity

We, Vari-Lite B.V., 10911 Petal Street, Dallas, Texas 75238, declare under our responsibility for the products contained herein are in conformity with the essential requirements of the following European Directives and harmonized standards:

Low Voltage Director (LVD), 2006/95/EC

EN 60589-2-17:1984+A1:1987+A2:1990 used in conjunction with 60598-1:2008/A11:2009

Electromagnetic Compatibility Directive (EMC), 2004//108/EC

EN 55022:2010, EN55024:2010

Safety Notice

It is extremely important to read ALL safety information and instructions provided in this manual and any accompanying documentation before installing and operating the products described herein. Heed all cautions and warnings during installation and use of this product.

Safety symbols used throughout this manual are as follows:



CAUTION advising of potential damage to product.



WARNING advising of potential injury or death to persons.

GENERAL INFORMATION PERTAINING TO PROTECTION AGAINST ELECTRICAL SHOCK, FIRE, EXPOSURE TO EXCESSIVE UV RADIATION, AND INJURY TO PERSONS CAN BE FOUND BELOW.

WARNING:

INSTRUCTIONS FOR CONTINUED PROTECTION AGAINST FIRE

1. VARI*LITE luminaires have been designed for use with specific lamp types. The VL4000 BeamWash Luminaire requires a certain type of lamp (see [“Replacement Items/Accessories” on page 8](#) for all lamp types). Installing another type or unapproved lamp may be hazardous.
2. Luminaires may be mounted on any type of surface as long as mounting instructions are followed. See instructions detailed in this manual.
3. Note distance requirement from combustible materials or illuminated objects for VARI*LITE luminaires.

WARNING:

INSTRUCTIONS FOR CONTINUED PROTECTION AGAINST ELECTRICAL SHOCK

1. VARI*LITE luminaires are designed for dry locations only. Exposure to rain or moisture may damage luminaire.
2. Disconnect power before servicing any VARI*LITE equipment.
3. Servicing to be performed by qualified personnel only.

WARNING:

INSTRUCTIONS FOR CONTINUED PROTECTION AGAINST EXCESSIVE EXPOSURE TO UV RADIATION

1. Many VARI*LITE luminaires use a lamp that produces UV radiation. DO NOT look directly at lamp.
2. It is hazardous to operate luminaires without lens or shield. Shields, lenses, or ultraviolet screens shall be changed if they have become visibly damaged to such an extent that their effectiveness is impaired. For example, by cracks or deep scratches.

WARNING:

INSTRUCTIONS FOR PROTECTION AGAINST INJURY TO PERSONS

1. Exterior surfaces of the luminaire will be hot during operation. Use appropriate safety equipment (gloves, eye protection, etc.) when handling and adjusting hot equipment and components.
2. Luminaires will have a hot lamp when operating. Disconnect power and allow lamp to cool before replacing.
3. Arc lamps emit ultraviolet radiation which can cause serious skin burn and eye inflammation. Additionally, arc lamps operate under high pressure at very high temperatures. Should the lamp break, there can exist a danger of personal injury and/or fire from broken lamp particles being discharged.
4. Wear eye protection when relamping.
5. Appropriate safety equipment (gloves, eye protection) should be used when handling damaged lamps.
6. If lamp is touched with bare hands, clean lamp with denatured alcohol and wipe with lint-free cloth before installing or powering up the luminaire.
7. The lamp shall be changed if it has become damaged or thermally deformed.

WARNING:

RF INTERFERENCE

1. This is a Class A product. In a domestic environment this product may cause radio interference, in which case, the user may be required to take adequate measures.

Sicherheitshinweise

Es ist äußerst wichtig, ALLE Sicherheitsinformationen und -hinweise in diesem Handbuch und dem beiliegenden Informationsmaterial zu lesen, bevor Sie die hierin beschriebenen Produkte installieren bzw. bedienen. Halten Sie bei der Installation und dem Einsatz dieses Produkts alle Warnhinweise und Vorsichtsmaßnahmen ein.

Folgende Sicherheitssymbole werden in diesem Handbuch verwendet:



VORSICHT - weist auf möglichen Produktschaden hin.



WARNUNG - weist auf mögliche Körperverletzung und Lebensbedrohung hin.

NACHSTEHEND FINDEN SIE ALLGEMEINE HINWEISE ÜBER SICHERHEITSVORKEHRUNGEN GEGEN ELEKTROSCHOCK, FEUER, ÜBERHÖHTE UV-STRAHLUNG UND KÖRPERVERLETZUNGEN.

WARNUNG:

HINWEISE ZUM FEUERSCHUTZ

1. VARI*LITE-Scheinwerfer sind ausschließlich für den Einsatz mit bestimmten Lampentyps. Achten Sie auf den Lampentyp, bevor Sie die jeweiligen Lampen ersetzen. Die Installation eines anderen Lampentyps kann gefährlich sein.
2. Scheinwerfer können auf jeder beliebigen Oberfläche montiert werden, solange Sie die Montageanweisungen befolgen. Detaillierte Hinweise finden Sie in diesem Handbuch.
3. Beachten Sie die Einhaltung des erforderlichen Sicherheitsabstandes der VARI*LITE-Scheinwerfer von brennbarem Material oder beleuchteten Objekten.

WARNUNG:

HINWEISE ZUM SCHUTZ GEGEN ELEKTROSCHOCK

1. VARI*LITE-Scheinwerfer eignen sich ausschließlich für trockene Standorte. Regen oder Feuchtigkeit können die Scheinwerfer beschädigen.
2. Unterbrechen Sie die Stromzufuhr, bevor Sie mit der Arbeit an VARI*LITE-Geräten beginnen.
3. Die Geräte sollten nur von qualifiziertem Personal gewartet werden.

WARNUNG:

HINWEISE ZUM SCHUTZ GEGEN ÜBERHÖHTE UV-STRAHLUNG

1. Viele VARI*LITE-Scheinwerfer verwenden die Lampentyp, der UV-Strahlen abgibt. SCHAUEN SIE NICHT direkt in die Lampe.
2. Es ist gefährlich, Leuchten ohne Linsen oder Blenden zu bedienen. Blenden, Linsen oder Ultraviolettshielder müssen ausgetauscht werden, sofern deren Schutzwirkung durch sichtbare Beschädigung (z. B. Sprünge oder Schrammen) eingeschränkt ist.

WARNUNG:

HINWEISE ZUM SCHUTZ GEGEN KÖRPERVERLETZUNGEN

1. Bei Betrieb sind die Außenflächen der Scheinwerfer heiß. Verwenden Sie bei der Bedienung von aufgeheizter Apparatur die jeweils geeignete Sicherheitsausrüstung (Handschuhe, Augenschutz etc.).
2. Bei Betrieb der Scheinwerfer ist die Lampe heiß. Unterbrechen Sie die Stromzufuhr und lassen Sie die Lampe abkühlen, wenn Sie diese austauschen.
3. Bogenlampen senden ultraviolette Strahlen aus, die Hautverbrennungen und Augenentzündungen verursachen können. Der Betrieb von Bogenlampen erfolgt unter Hochdruck und bei hohen Temperaturen. Sollte die Lampe zerbrechen, besteht die Gefahr von Körperverletzung bzw. von Feuer, das von Lampenteilen ausgelöst werden kann.
4. Tragen Sie beim Austausch der Lampen einen Augenschutz.
5. Die geeignete Sicherheitsausrüstung (Handschuhe, Augenschutz) sollte beim Umgang mit beschädigten Lampen verwendet werden.
6. Wenn die Lampe mit bloßen Händen berührt wird, reinigen Sie sie mit denaturiertem Alkohol und einem fusenfreien Tuch, bevor Sie die Scheinwerfer installieren oder in Betrieb nehmen.
7. Wenn die Lampe beschädigt oder durch Hitzeeinwirkung deformiert ist, muß diese ausgetauscht werden.

WARNUNG:

HF-INTERFERENZ

1. Es handelt sich um ein Produkt der Klasse A. In einer Wohnumgebung kann das Produkt Hochfrequenzstörungen verursachen. In diesem Fall müssen eventuell geeignete Maßnahmen getroffen werden.

Notes de sécurité

Avant de procéder à l'installation des produits décrits dans ce guide et de les mettre en marche, il est extrêmement important de lire TOUS les renseignements et TOUTES les directives de sécurité contenues dans ce guide ainsi que toute documentation jointe. Tenir compte de tous les avertissements et suivre toutes les précautions pendant l'installation et l'utilisation de cet appareil.

Les symboles de sécurité utilisés dans ce guide sont les suivants :



ATTENTION Ce symbole annonce que l'appareil risque d'être endommagé.



AVERTISSEMENT Ce symbole annonce qu'il y a risque d'accident grave ou même fatal.

CETTE SECTION CONTIENT DES INFORMATIONS GÉNÉRALES POUR SE PROTÉGER CONTRE LES DÉCHARGES ÉLECTRIQUES, LES INCENDIES, L'EXPOSITION EXCESSIVE AUX RAYONS UV ET TOUT AUTRE ACCIDENT POUVANT ENTRAÎNER DES BLESSURES.

AVERTISSEMENT:

DIRECTIVES POUR SE PROTÉGER CONTRE LES INCENDIES

1. Les luminaires VARI*LITE ont été conçus pour être utilisés uniquement avec certaines type de lampes. Vérifier le type de lampe avant de remplacer les lampes. L'installation d'un autre type de lampe peut poser un danger.
2. Les luminaires peuvent être fixés sur tout type de surface tant que les directives de montage sont respectées. Voir les explications détaillées dans ce guide.
3. Vérifier la distance à respecter entre les matériaux combustibles ou les objets illuminés et les luminaires VARI*LITE.

AVERTISSEMENT:

DIRECTIVES POUR SE PROTÉGER CONTRE LES DÉCHARGES ÉLECTRIQUES

1. Les luminaires VARI*LITE sont conçus pour une utilisation au sec uniquement. Une exposition à la pluie et à l'humidité risque d'endommager le luminaire.
2. Débrancher l'appareil avant de procéder à la révision de tout matériel VARI*LITE.
3. Les révisions doivent être effectuées uniquement par des personnes qualifiées.

AVERTISSEMENT:

DIRECTIVES POUR SE PROTÉGER CONTRE UNE EXPOSITION EXCESSIVE AUX RAYONS UV

1. Plusieurs luminaires VARI*LITE utilisent une lampe qui produit des rayons UV. NE PAS fixer son regard sur la lampe.
2. L'utilisation des luminaires sans lentille ou blindage pose des risques. Tous blindages, lentilles ou écrans ultraviolet visiblement endommagés au point que leur efficacité en est affectée doivent être remplacés, par exemple s'il y a des fissures ou de profondes rayures.

AVERTISSEMENT:

DIRECTIVES POUR SE PROTÉGER CONTRE LES ACCIDENTS POUVANT ENTRAÎNER DES BLESSURES

1. Les surfaces externes du luminaire deviennent brûlantes quand l'appareil est en marche. Pour manœuvrer ou ajuster des appareils brûlants et leurs composants, se protéger suffisamment (gants, protection pour les yeux, etc.).
2. La lampe du luminaire est brûlante lorsqu'il est en marche. Débrancher le courant et attendre que la lampe ait refroidi avant de la remplacer.
3. Les lampes à arc émettent des rayons ultraviolets pouvant causer de graves brûlures sur la peau et une inflammation des yeux. De plus, les lampes à arc fonctionnent sous haute tension à de très hautes températures. Si la lampe se casse, les particules de la lampe cassée peuvent causer blessures et/ou incendie en s'éparpillant.
4. Se protéger les yeux pour remplacer la lampe.
5. Utiliser des appareils de protection appropriés (gants, protection des yeux) pour manier des lampes endommagées.
6. Si la lampe a été touchée avec des mains nues, la nettoyer avec de l'alcool dénaturé et l'essuyer avec un chiffon non-pelucheux avant d'installer ou de brancher le luminaire.
7. Si la lampe a été endommagée ou a reçu une déformation thermique, elle doit être remplacée.

AVERTISSEMENT:

INTERFÉRENCE RF

1. Cet appareil est de Classe A. Dans un environnement domestique, cet appareil peut causer des interférences radio, et si c'est le cas, l'utilisateur peut avoir à prendre des mesures adéquates.

Aviso sobre Seguridad

Es muy importante leer TODA la información e instrucciones sobre seguridad que se indica en este manual así como en los documentos adjuntos antes de instalar y operar los productos descritos. Se debe prestar atención a todos los avisos y advertencias durante la instalación y uso de este producto.

Los símbolos de seguridad usados en este manual son los siguientes:



CUIDADO, indica posibles daños al producto.



ADVERTENCIA, indica posibles lesiones o muerte a las personas.

LA INFORMACIÓN GENERAL RELACIONADA A LA PROTECCIÓN CONTRAGOLPES DE CORRIENTE ELÉCTRICA, INCENDIO, EXPOSICIÓN EXCESIVA A RADIACIÓN ULTRA VIOLETA Y LESIONES A LAS PERSONAS SE PUEDE ENCONTRAR SEGUIDAMENTE:

ADVERTENCIA:

INSTRUCCIONES PARA PROTECCIÓN CONTINUA CONTRA INCENDIO

1. Las luminarias VARI*LITE han sido diseñadas para ser usadas solamente con algunas lámparas. Tome nota del tipo de lámpara antes de reemplazarla. Instalación de otro tipo de lámpara puede ser peligroso.
2. Las luminarias se pueden instalar en cualquier tipo de superficie siempre que se sigan las instrucciones de instalación. Vea las instrucciones detalladas en este manual.
3. Tome nota de los requerimientos de distancia de materiales combustibles u objetos iluminados para las luminarias VARI*LITE.

ADVERTENCIA:

INSTRUCCIONES PARA PROTECCIÓN CONTINUA CONTRA CHOQUE ELÉCTRICO

1. Las luminarias VARI*LITE están diseñadas solamente para lugares secos. La exposición a la lluvia o humedad pueden dañar la luminaria.
2. Desconecte la energía antes de dar servicio a cualquier equipo de VARI*LITE.
3. El servicio debe ser realizado solamente por personal calificado.

ADVERTENCIA:

INSTRUCCIONES PARA PROTECCIÓN CONTINUA CONTRA LA EXPOSICIÓN EXCESIVA DE RADIACIÓN ULTRA VIOLETA

1. Muchas luminarias VARI*LITE usan un tipo de lámpara que produce radiación UV. NO mire directamente a la lámpara.
2. Es peligroso operar luminarias sin lentes o protectores. Debe cambiar los protectores, lentes o pantallas ultravioletas si se aprecia que han sido dañadas, y que su efectividad pudiera estar deteriorada. Por ejemplo, si tuvieran rajaduras o raspaduras profundas.

ADVERTENCIA:

INSTRUCCIONES PARA PROTECCIÓN CONTRA LESIONES DE PERSONAS

1. Las superficies exteriores de las luminarias están calientes durante su operación. Use un equipo de seguridad apropiado (guantes, protección para los ojos, etc.) cuando haga ajustes en el equipo y componentes que están calientes.
2. Cuando las luminarias están en operación la lámpara estará muy caliente. Desconecte la energía y deje que la lámpara se enfríe antes de reemplazarla.
3. Las lámparas de arco emiten radiaciones ultravioletas que pueden ocasionar serias quemaduras a la piel e inflamación a los ojos. Además, las lámparas de arco operan a alta presión y muy alta temperatura. Si la lámpara se rompe, puede existir el peligro de lesiones al personal o un incendio ocasionado por las partículas de la lámpara rota que se caen.
4. Use protección para los ojos cuando vuelve a colocar una lámpara nueva.
5. Use un equipo de seguridad apropiado (guantes, protección para los ojos, etc.) cuando trabaje con lámparas dañadas.
6. Si toca la lámpara con las manos, limpie la lámpara con alcohol desnaturalizado y con tela sin pelusas antes de instalar o volver a conectar la luminaria.
7. Cambie la lámpara si está dañada o deformada termicamente.

ADVERTENCIA:

INTERFERENCIA RF

1. Este es un producto de Clase A. En el ambiente de la casa este producto puede ocasionar radiointerferencia, en cuyo caso, el usuario debe tomar las medidas adecuadas.

安全性に関する注意事項

ここに記載されている製品を取り扱う場合は、まず本マニュアルおよび付属のマニュアルの安全性に関する情報と説明をすべてお読みください。また、実際に本製品を取り付けたり使用する際には、すべての注意事項および警告に留意して作業してください。

本マニュアルでは、以下の安全マークを使用しています。



注意：製品に損傷を与える危険性があります。



警告：人身事故につながる危険性があります。

感電、火災、UV放射に対する過度の露出、および人身事故を防ぐための一般的な情報については、以下の説明をお読みください。

警告：

火災の発生を防ぐためのヒント

1. VARI*LITE® 照明器具は、ランプを使用するように設計されています。ランプを交換する際は、ランプの種類（など）を確認するようにしてください。他の種類のランプを取り付けると危険です。
2. 照明器具は、本マニュアルの指示に従って操作するかぎり、どのようなタイプの表面にでも取り付けることができます。詳細については、本マニュアルを参照してください。
3. ヒューズを交換する場合は、同じヒューズ（同じ種類、同じクラス）を使用してください。
4. VARI*LITE® 照明器具は、可燃性物質または他の光源から必要な距離だけ離して配置してください。

警告：

感電を防ぐためのヒント

1. VARI*LITE® 照明器具は、乾燥した環境で使用するよう設計されています。雨で濡れる場所や湿気の多い場所に取り付けると、照明器具が傷むことがあります。
2. VARI*LITE® 照明器具を修理点検する場合は、必ず先に電源を切ってください。
3. 照明器具の修理点検は、資格を持つ技師のみが行うようにしてください。

警告：

過度の UV 放射にさらされないためのヒント

1. VARI*LITE® 照明器具の多くは、UV 放射を生ずる HID タイプのランプを使用しています。ランプを直視することは避けてください。
2. レンズまたはシールドを使わずに照明器具を点灯すると危険です。レンズ、シールド、紫外線画面は、ひび割れや深い引っかき傷などにより、その効力が損なわれるようになったら取り替えるようにします。

警告：

人身事故を防ぐためのヒント

1. 照明器具が点灯しているときは、その外側が熱くなります。熱くなった器具やコンポーネントを取り扱う際には、適切な防具（手袋や保護用眼鏡）を使用してください。
2. 照明器具が点灯しているときは、そのランプが熱くなります。ランプを交換する場合は、照明器具の電源を切り、ランプの温度が下がるまで待ってください。ランプの裏ぶたをあけると、遮断スイッチが働いて、ランプの電源が切れる場合があります。
3. アーク灯は紫外線を放射します。この紫外線によって、ひどい火傷を負ったり、目の炎症を起こすことがあります。さらに、アーク灯は、高圧高温の状態です。そのため、万一アーク灯が破損すると、飛び散った破片で人身事故や火災が発生する危険性があります。
4. 再点灯するときには、保護用眼鏡を着用してください。
5. 損傷したランプを取り扱う場合は、適切な防具（手袋や保護用眼鏡）を着用してください。
6. 手袋を着用せずに直接手でランプを触った場合は、変性アルコールを使ってランプをきれいにし、糸くずの出ない布で拭いてから照明器具を取り付け、電源を入れるようにします。
7. 傷がついたランプや熱によって変形したランプは取り替えてください。

警告：

RF 干渉

1. 本製品は Class A に分類されます。本製品は、家庭環境において無線干渉を起こす可能性があります。その場合、使用者は適切な処置を取らなければならないことがあります。

Table of Contents

Introduction

| | |
|-------------------------------|---|
| About This Manual | 1 |
| Additional Documentation..... | 2 |
| Text Conventions | 2 |
| Customer Service | 3 |

Chapter 1. Description

Features

| | |
|----------------|---|
| Overview | 6 |
|----------------|---|

Components

| | |
|------------------------------------|---|
| Included Items..... | 8 |
| Replacement Items/Accessories..... | 8 |
| Luminaire Components..... | 9 |
| Major Components | 9 |

Chapter 2. Installation

Power and Data Cabling Requirements

| | |
|--|----|
| Power | 12 |
| Current vs. Voltage..... | 14 |
| Data Cables | 15 |
| Recommended Cable Types/Manufacturers..... | 16 |
| Termination Connector..... | 16 |

Installation Procedures

| | |
|--|----|
| Installing Lamp | 17 |
| CAUTIONS & WARNINGS | 17 |
| Align Lamp For Maximum Beam Irradiance | 19 |
| Hanging the Luminaire | 20 |
| Floor Mounting the Luminaire..... | 24 |
| Connecting Data and Power..... | 24 |

Powering Up

| | |
|--------------------------|----|
| Power-Up Procedure | 25 |
|--------------------------|----|

Addressing

| | |
|---|----|
| Program Starting Address | 26 |
| Program Starting Address Without Calibrating Luminaire..... | 26 |

Transporting

| | |
|---|----|
| Overview | 27 |
| Transportation and Shipping Case Requirements | 27 |

Chapter 3. Operation

Color Control & Gobos

| | |
|-------------------|----|
| Color Mixing..... | 30 |
|-------------------|----|

| | |
|---|----|
| Fixed Color Wheel 1 | 30 |
| Fixed Color Wheel 2 | 31 |
| Gobos | 31 |
| Rotating Gobo Wheel 1 | 32 |
| Rotating Gobo Wheel 2 | 33 |
| Animation Wheel | 34 |
| Animation Wheel - Concurrent | 34 |
| DMX Operation | |
| VL4000 BeamWash Channel Mapping | 35 |
| Enhanced 16-Bit Channel Mapping (Default)..... | 35 |
| 16-Bit Channel Mapping | 40 |
| Fixture Shutdown | 44 |
| Luminaire Timing | |
| Luminaire Timing Channel Information | 45 |
| RDM Parameter IDs | |
| VL4000 BeamWash Luminaire RDM Parameter IDs | 53 |
| Updating Software | |
| PEGASUS Software | 56 |
| Application | 56 |
| Computer Requirements | 56 |
| Installing PEGASUS Software | 56 |
| Troubleshooting | 57 |
| Upload Cable LED Status Messages..... | 57 |
| Upload Cable Warning (Error) Message..... | 58 |
| Installing or Updating Luminaire Firmware | 58 |
| USB Upload via USB Port | 58 |
| Using PEGASUS Uploader..... | 58 |
| Important Notes & Warnings: | 58 |
| Transferring Software From Luminaire to Luminaire | 60 |

Chapter 4. Menu System

| | |
|--|----|
| Menu Operation | |
| LCD Display and Menu System | 64 |
| Menu Controls..... | 64 |
| LCD Display and Menu System Operation..... | 65 |
| DMX Address..... | 65 |
| Operational Modes - Standard and Studio..... | 65 |
| Other LCD Display Features..... | 66 |
| LCD Menu Battery Operation | 66 |
| Status Bar..... | 66 |
| LCD Menu Proximity Sensor | 66 |
| Menu Tree | 67 |
| Menu System Functions..... | 69 |
| Self Tests | |
| Running Parameter Tests | 73 |
| Diagnostic Tests | 74 |
| Test Descriptions | 74 |

Service Menu Items

- Set Tilt Cal 75
- Gobo Offset..... 76
- USB Logging 76

Appendix A. Maintenance

Equipment Handling

- Locations/Use..... 80
- Lamps..... 80
 - Servicing..... 80
 - Heat..... 80
 - Lamp Life..... 80
- Solid State Electronics 81
 - Electrostatic Discharge (ESD)..... 81
 - Printed Circuit Boards (PCBs) 81

Troubleshooting

- Error Messages..... 82
- Troubleshooting Guide..... 83

Routine Maintenance

- Lamp Removal and Installation 84
 - CAUTIONS & WARNINGS 84
- Fixed Color Wheel Filter Removal and Installation 86
- Rotating Gobo Removal and Installation..... 88
- Animation Wheel Removal and Installation..... 91
- Prism Removal and Installation 93
- Cleaning Optical Lenses and Filters 95

Appendix B. Technical Specifications

- Mechanical 97
- Optical..... 98
- Operational..... 100



Introduction

About This Manual

This manual provides necessary information regarding safety, installation, operation and routine maintenance for VARI*LITE VL4000 BeamWash Luminaire. Familiarizing yourself with this information will help you to get the most out of your product.



WARNING: It is important to read ALL accompanying safety and installation instructions to avoid damage to the product and potential injury to yourself or others.

This manual covers the following models:

| Model | Part Number | Lamp Type |
|-----------------|--------------|---|
| VL4000 BeamWash | 20.9704.0002 | 1200W Short Arc, Philips MSR Gold FastFit |

Notes:

- For complete product description, features, and specifications, refer to [“Technical Specifications” on page 97](#).
- For power requirements, refer to [“Current vs. Voltage” on page 14](#).
- VL4000 BeamWash Luminaire accepts glass gobos only. Use of metal gobos will void the luminaire’s warranty.

Additional Documentation

Note: Performing maintenance procedures may void the product warranty. Refer to the Vari-Lite Limited Warranty card included in the product shipping package for more information.

For more information on installing DMX512 control systems, the following publication is available for purchase from the United States Institute for Theatre Technology (USITT), "Recommended Practice for DMX512: A Guide for Users and Installers, 2nd edition" (ISBN: 9780955703522). USITT Contact Information:

USITT
315 South Crouse Avenue, Suite 200
Syracuse, New York 13210-1844 USA
Phone: 800-938-7488 or +1-315-463-6463
Fax: 866-398-7488 or +1-315-463-6525
Web Site: www.usitt.org

Text Conventions

The following styles and meanings are used throughout this manual:

| Style | Meaning |
|----------------------|--|
| [Button] | Front panel button. Example: Press [ESC]. |
| [Up] / [Down] arrows | Press either [Up] or [Down] arrow button at Menu Display. |
| LAMP | LCD Menu Display read-out. Example: Press [Up] / [Down] arrows until LAMP appears. |

Customer Service

Our Goal

At Vari-Lite, we are committed to providing you the highest quality in customer service. Our comprehensive resources are available to help your business succeed and ensure you get the full benefit of being a Vari-Lite customer. Whether your needs are telephone troubleshooting assistance, product training or technical service, our full-time staff of experienced professionals are on-hand to provide support.

How to Reach Us

For assistance in your area, call the dealer from which your product was purchased.

or Contact an Authorized Service Center

or Contact the Vari-Lite Customer Service Department, 7am - 6pm CST Monday through Friday, at the following:

phone: 1-877-VARI-LITE (1-877-827-4548) or +1-214-647-7880

e-mail: entertainment.service@philips.com

Additional Resources

For additional resources and documentation, please visit our website at www.vari-lite.com and follow the Support link.

Notes

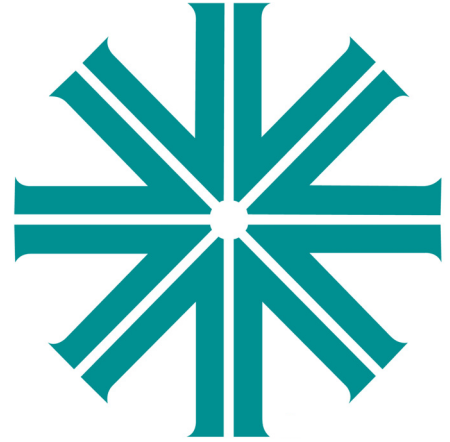

CHAPTER 1.

Description

This chapter contains descriptions of luminaire features and components, along with a list of accessories which are available.

- **Features**
- **Components**

Features

Overview

VL4000 BeamWash Luminaire feature highlights:

Color System

A three filter CYM cross fading system capable of extremely smooth movements at both slow and fast speeds, and a variable CTO color temperature correction system.

Fixed Color Wheels

Two opposing fixed color wheels each with five interchangeable color filters are capable of producing multi-color effects and variable wheel rotations.

Wash Mode

- **Wash Zoom Optics:** A 6-element 6:1 zoom optics system, covering a range from 10° to 60°.
- **Beam Shaping:** Unique indexing and rotating beam shaping alters output from round to elliptical with minimal light loss.
- **Edge and Hot Spot Control:** Variable hot / edge adjustment provides a multitude of different wash styles.

Beam Mode

- **Beam Zoom Optics:** A 6-element 10:1 zoom optics system, covering a range from 4° to 40°.
- **Beam Size Control:** A mechanical iris provides continuous beam size control for rapid and smooth timed beam angle changes. Near zero degree beam angle is possible with nearly fully closed iris.
- **Rotating Gobo Wheels:** Two gobo wheels combine to each offer seven rotatable, indexable gobo positions and one open position.
- **Animation Wheel:** A dynamic animation wheel offers unique rotatable, indexable patterns with variable motion control from horizontal to vertical.
- **Rotating Prism:** Independent rotating and indexing 5-facet step prism.
- **Lenticular Effect:** Unique indexing and rotating lenticular effect alters output from round to rectangular and to create extruded gobo imagery.
- **Edge and Pattern Focus:** Variable beam focus to soften edges of gobos or s. Remarkable depth of field capability allows morphing effects between gobos and the animation wheel.

Shaft Mode

- **Shaft Optics:** 4° adjustable to near 0° with iris.
- **Beam Size Control:** A mechanical iris provides continuous beam size control for rapid and smooth timed beam angle changes.

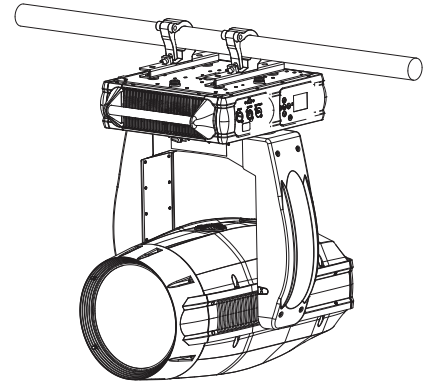

*Note, truss hooks shown are sold separately.
Truss and pipe by others.*

- **Rotating Gobo Wheels:** Two gobo wheels combine to each offer seven rotatable, indexable gobo positions and one open position.
- **Animation Wheel:** A dynamic animation wheel offers unique rotatable, indexable patterns with variable motion control from horizontal to vertical.
- **Rotating Prism:** Independent rotating and indexing 5-facet step prism.
- **Lenticular Effect:** Unique indexing and rotating lenticular effect alters output from round to rectangular and to create extruded gobo imagery.

Edge and Pattern Focus

Variable beam focus to soften edges of gobos or s. Remarkable depth of field capability allows morphing effects between gobos and the animation wheel.

Intensity Control

Full field dimming designed for smooth timed fades as well as quick dimming effects.

Strobe

High-performance dual blade strobe system capable of ultra-fast operation.

Pan and Tilt

Smooth, time-controlled continuous motion by way of three-phase stepper motor systems.

- Range: Pan - 540°, Tilt - 270°.
- Accuracy: 0.3° resolution.

Weights

Unit weighs (luminaire only, without accessories) 101 lbs (45.8 kg).

Spacing

Unit hangs on 30 inch (762 mm) centers.

Operational Temperature

- Standard Mode: -20° to +104° F (-29° to +40° C)
- Studio Mode: -20° to +122° F (-29° to +50° C)

Control

- DMX: Completely compatible with a wide variety of DMX512 consoles.
- DMX Channels: 46 (Enhanced 16-bit mode) / 41 (16-bit mode)
- RDM Control: Completely compatible with a wide variety of RDM devices.

Power Requirements:

Standard AC power distribution from 200 - 240VAC, 50/60 Hz. The unit requires up to 11.0A depending on the AC supply voltage.

Note: *For a breakdown of total luminaire current draw, see [“Current vs. Voltage” on page 14.](#)

Components

Included Items

The following illustration shows all items included with the luminaire:

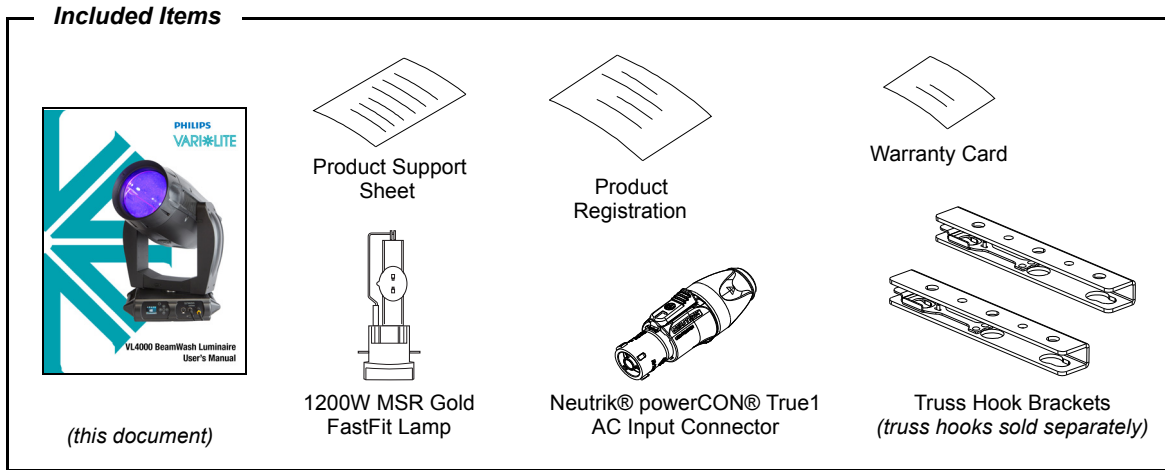

Figure 1-1: VL4000 BeamWash Luminaire Included Items

Replacement Items/Accessories

The following optional and/or replacement items can be ordered directly from your Authorized VARI*LITE Dealer. When ordering, please order by the Vari-Lite part number.

| Vari-Lite Part No. | Accessory |
|--------------------|--|
| PCT1BE | AC Input Cable, Neutrik® powerCON® True1 with Bare End (no connector), 1 Meter |
| PCT1GTL08 | AC Input Cable, Neutrik® powerCON® True1 with Twist Lock (Male), 250V, 1 Meter |
| PCT1GP | AC Input Cable, Neutrik® powerCON® True1 with Stage Pin (Male), 1 Meter |
| PEGASUS | Luminaire Programming Kit |
| 22.9620.0194 | Safety Cable Assembly |
| 25.9661.0057 | DMX Termination Connector Assembly |
| 55.6840.0001 | Truss Hook, Mega-Clamp, Round and Square |
| 55.6841.0001 | Truss Hook, Mega-Claw for 2" Round Tube |
| 71.9704.1200 | 1200W Short Arc Lamp, Philips MSR Gold Fast-Fit* |

*For approved lamp types, see the latest version of Vari-Lite technical notice TN-248 in the product downloads section on the Vari-Lite web site, www.vari-lite.com.

Luminaire Components

Below is a brief description of the major components and sub assemblies of the VL4000 BeamWash Luminaires.

Major Components

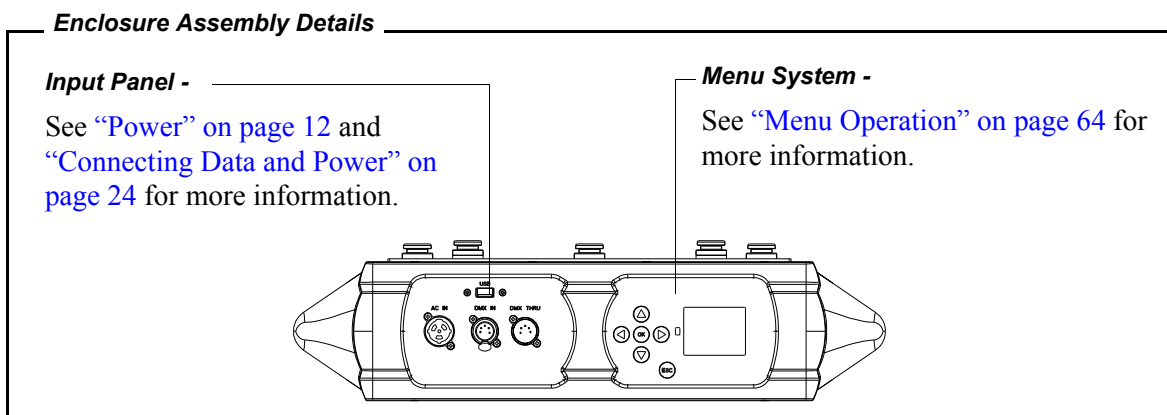
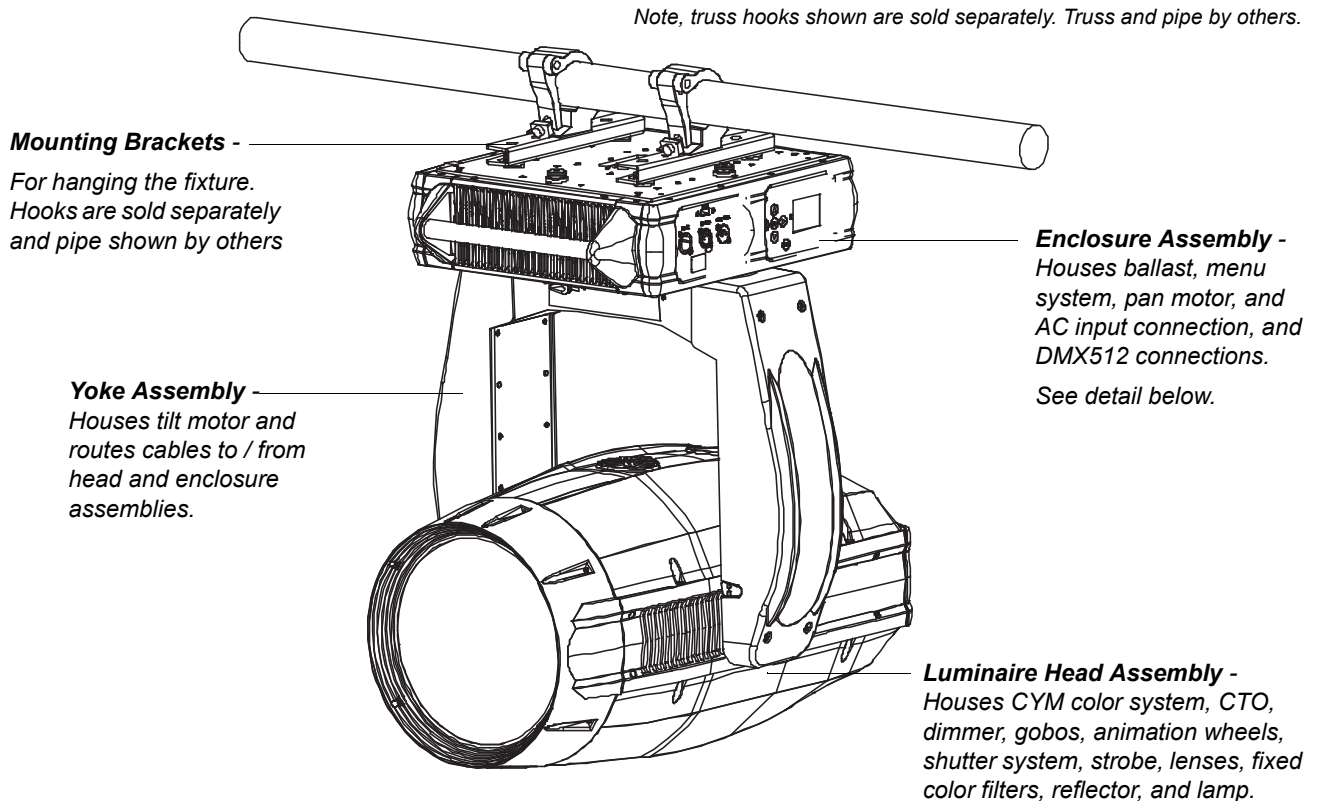
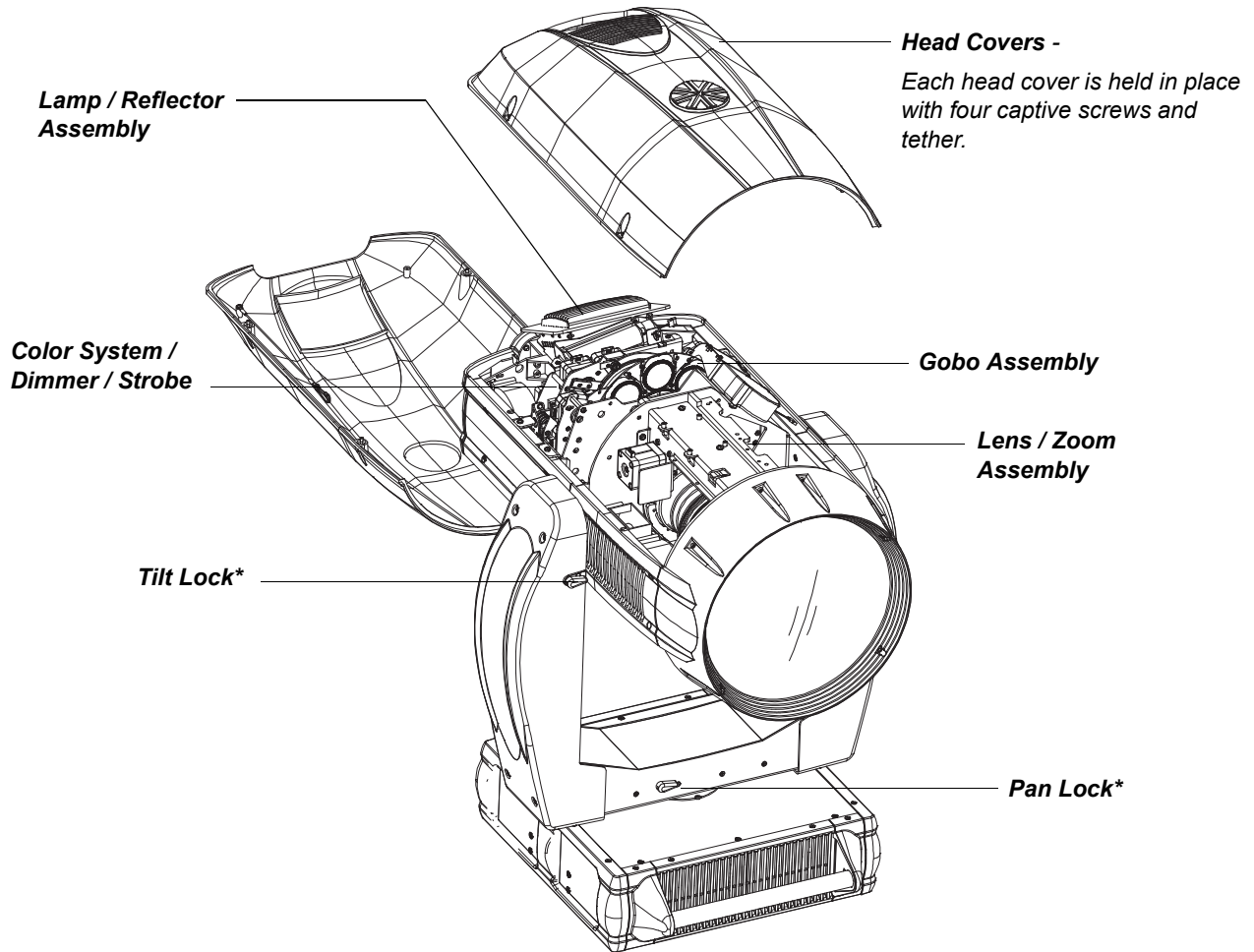

Figure 1-2: Major Components

Sub Assemblies



CAUTION: *Pan and tilt locks must be disengaged before powering and operating luminaire.

NOTE: ** 1200W Philips MSR Gold FastFit lamp (rated for 800-1400W operation) running at 1400W in Standard mode or 1200W in Studio mode.

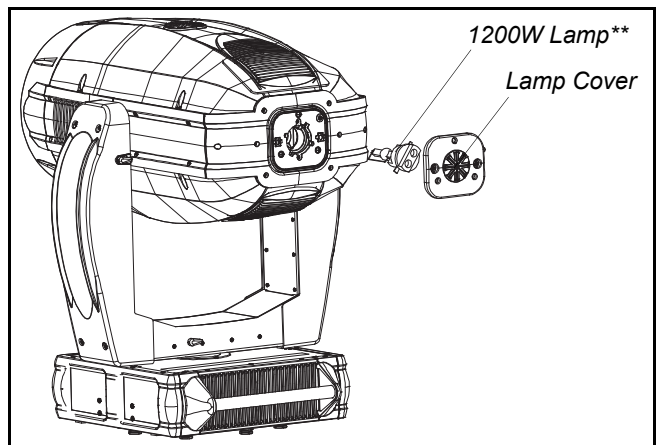
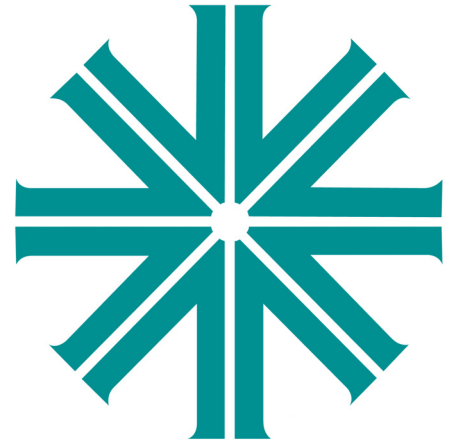

Figure 1-3: Sub Assemblies



CHAPTER 2.

Installation

This chapter contains instructions for installation of the luminaire. It includes connecting power and data, along with instructions for powering up the luminaire for the first time and addressing it within your system.

- **Power and Data Cabling Requirements**
- **Installation Procedures**
- **Powering Up**
- **Addressing**
- **Transporting**

Note: Please refer to the following [“Set Tilt Cal”](#) on page 75 and [“Gobo Offset”](#) on page 76 for additional set up information.

Power and Data Cabling Requirements

Power

The luminaire requires standard AC power distribution from 200-240 VAC, 50/60 Hz. Current required depends on the AC supply voltage and product model. Refer to “[Current vs. Voltage](#)” on [page 14](#) for all models covered in this manual.



Note: The mating Neutrik® powerCON® True1 connector is supplied, however, you will need to purchase or construct a cable appropriate for your application. Available power input cables is found in “[Replacement Items/Accessories](#)” on [page 8](#).

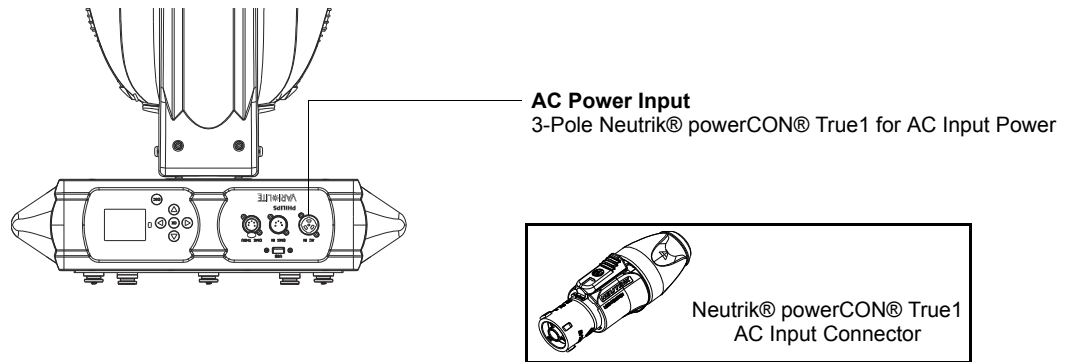

Figure 2-1: Power Connector

Depending on the application, the luminaire’s AC input cable may require a different connector. If required, install a new connector meeting your requirements using the following wire color code reference:

| Wire* | Connection |
|--------------|------------|
| Green/Yellow | AC Ground |
| Blue | AC Neutral |
| Brown | AC Line |

* International (Harmonized) Standard



WARNING: DO NOT connect to three-phase service in countries with 240 volt power.

For single-phase power at 208 to 240 volts RMS:

| Connection | Pin |
|----------------|-----|
| AC Neutral | X |
| AC Line | Y |
| Ground (Earth) | G |

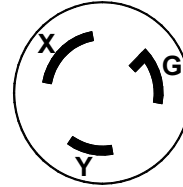

For three-phase power at 208 volts RMS:

| Connection | Pin |
|----------------|-----|
| Phase 1 | X |
| Phase 2 | Y |
| Ground (Earth) | G |

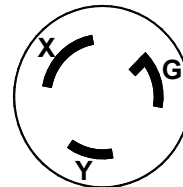

WARNING: It is not recommended to power any VARI*LITE luminaire from a dimmer - even in 'NONDIM' mode. Dimmer and non-dim modules are not suitable sources of power because their output modifies the AC wave form. This may work for a short time, but will eventually result in power problems, luminaire mis-operation and/or failure and may void the luminaire's warranty.

Current vs. Voltage

Table 2-1, VL4000 BeamWash Luminaire - Current vs. Voltage (1200W Lamp*) provides the luminaire's current draw at specific voltages. Total Luminaire Current is calculated with the lamp on and all motors sequencing.



WARNING: It is the responsibility of the user to adequately protect supply source with a correct size and type circuit breaker and not overload circuits. **AVERTISSEMENT:** Il est de la responsabilité de l'utilisateur de protéger adéquatement la source d'alimentation avec une taille correcte et le disjoncteur de type et surchargez pas les circuits.*

Table 2-1: VL4000 BeamWash Luminaire - Current vs. Voltage (1200W Lamp*)

| AC Voltage @ 60Hz | Total Luminaire Current (Motor + Lamp Current) |
|-------------------|--|
| 200V | 11.0A |
| 210V | 10.5A |
| 220V | 10.0A |
| 230V | 9.6A |
| 240V | 9.2A |

Note: *1200W Philips MSR Gold FastFit lamp (rated for 800-1400W operation) running at 1400W in Standard mode or 1200W in Studio mode.



WARNING: It is not recommended to power any VARI*LITE luminaire from a dimmer - even in 'NONDIM' mode. Dimmer and non-dim modules are not suitable sources of power because their output modifies the AC wave form. This may work for a short time, but will eventually result in power problems, luminaire mis-operation and/or failure and may void the luminaire's warranty.

Data Cables

The luminaire is equipped with two, 5-pin XLR connectors for DATA IN and DATA THRU (out) applications. DATA IN requires a 5-pin, female XLR connector and DATA THRU requires a 5-pin, male XLR connector. When purchasing or constructing data cables, it is important that not only the correct cable type be used, but also quality cable to ensure a reliable DMX512 system. Your cabling should meet the following USITT DMX specification requirements:

- Suitable for use with EIA485 (RS485) operation at 250k baud.
- Characteristic impedance 85-150 ohms, nominally 120 ohms.
- Low capacitance.
- Two twisted pairs.
- Foil and braid shielded.
- 24 AWG min. gauge for runs up to 1000 feet (300m).
- 22 AWG min. gauge for runs up to 1640 feet (500m).

Note: Microphone type cables and other general purpose, two-core audio or signal cables are not suitable for use with DMX512.

Refer to the USITT Recommended Practice for DMX512 guide for additional information regarding DMX512 systems. How to obtain a copy is detailed in [“Additional Documentation” on page 2.](#)

The XLR 5-pin connectors should be wired as follows:

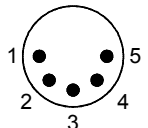
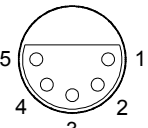
| Pin/Wire Code to XLR Connectors | | | | | | |
|--|---|---|---|---|---|--|
| Data Thru Cable Pinout  Male Conn. | Pin 1 Foil & Braided Shield | Pin 2 1st conductor of 1st twisted pair Data (-) | Pin 3 2nd conductor of 1st twisted pair Data (+) | Pin 4 1st conductor of 2nd twisted pair Data (-) | Pin 5 2nd conductor of 2nd twisted pair Data (+) | Data In Cable Pinout  Female Conn. |

Recommended Cable Types/Manufacturers

These are only a few of the suitable cable types. Any quality EIA485, twisted pair, 120 ohm, shielded cable will also work.

| Type | Pairs | ZΩ* | Jacket | AWG | Use | Temp (F) |
|-----------------------|-------|-----|--------------|------------|-------------------------|----------|
| Belden Cables | | | | | | |
| 1215A | 2 | 150 | PVC | 26 | IBM Type 6 Office cable | 75 |
| 1269A | 2 | 100 | PTFE | 22 (Solid) | High Temp, Plenum cable | 200 |
| 8102 | 2 | 100 | PVC | 24 | UL2919 | 80 |
| 8132 | 2 | 120 | PVC | 28 | UL2919 | 80 |
| 8162 | 2 | 100 | PVC | 24 | UL2493 | 60 |
| 82729 | 2 | 100 | PTFE | 24 | High Temp, Plenum cable | 200 |
| 88102 | 2 | 100 | PTFE | 24 | High Temp, Plenum cable | 200 |
| 89696 | 2 | 100 | PTFE | 22 | High Temp, Plenum cable | 200 |
| 89729 | 2 | 100 | PTFE | 24 | High Temp, Plenum cable | 200 |
| 89855 | 2 | 100 | PTFE | 22 | High Temp, Plenum cable | 200 |
| 9729 | 2 | 100 | PVC | 24 | UL2493 | 60 |
| 9804 | 2 | 100 | PVC | 28 | UL2960 | 60 |
| 9829 | 2 | 100 | PVC | 24 | UL2919 | 80 |
| 9842 | 2 | 120 | PVC | 24 | UL2919 | 80 |
| Proprex Cables | | | | | | |
| PC224P | 2 | 110 | Polyurethane | 22 | Heavy Duty and Portable | 105 |
| PC224T | 2 | 110 | PVC | 22 | UL2464 | 105 |
| PC226T | 3 | 110 | PVC | 22 | UL2464 | |

* Characteristic Impedance

Termination Connector

A XLR termination connector is required at the last luminaire (or "far end of the line") to prevent signal reflections. Signal reflections may cancel out the signal at certain line lengths, resulting in errors. The terminator is also necessary for software downloads and running tests on multiple luminaires. To construct your own connector, you will need the following components:

- 5-pin, male XLR connector.
- Two 1/4W 5% 120 ohm resistors.

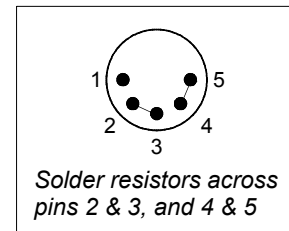

Note: A male termination connector is available as an accessory from Vari-Lite. See [“Replacement Items/Accessories”](#) on page 8.

Installation Procedures

Installing Lamp

In the event the lamp was packed separately during shipment, follow the procedure in this section. For lamp removal and replacement, refer to “[Lamp Removal and Installation](#)” on page 84.



WARNING: Disconnect fixture before relamping. Déconnectez le projecteur avant que le changement de lampe.



CAUTIONS & WARNINGS

- Wear cotton gloves or other covering while installing lamp. Touching lamp glass with bare fingers will leave oil and may cause the lamp to explode or reduce lamp life. If touched, use isopropyl alcohol and cotton cloth to thoroughly clean glass portion of lamp.
- Hot Lamp. Luminaire must remain powered on for 5 minutes after dousing lamp. Do not open for 5 minutes after switching off. Lampe chaude. Le luminaire doit rester en marche pendant 5 minutes après avoir éteindre la lampe. Ne pas ouvrir pendant 5 minutes après la coupure.
- Risk of exposure to excessive ultraviolet radiation. Do not operate without complete lamp enclosure in place or when lens is damaged. Risque d'exposition aux rayonnements ultraviolets excessifs. Ne pas faire fonctionner sans le boîtier complet de lampe mis en place ou lorsque l'objectif est endommagé.

To install lamp:

- Step 1. Ensure power is completely removed from luminaire.
- Step 2. Remove lamp from shipping box.
- Step 3. Set the luminaire head horizontally.
- Step 4. Engage tilt lock to secure luminaire head in position.
- Step 5. At back of luminaire, using #2 Phillips screwdriver, remove lamp socket cover by loosening the two quarter-turn captive screws. Note: lamp socket cover is connected with a safety tether.

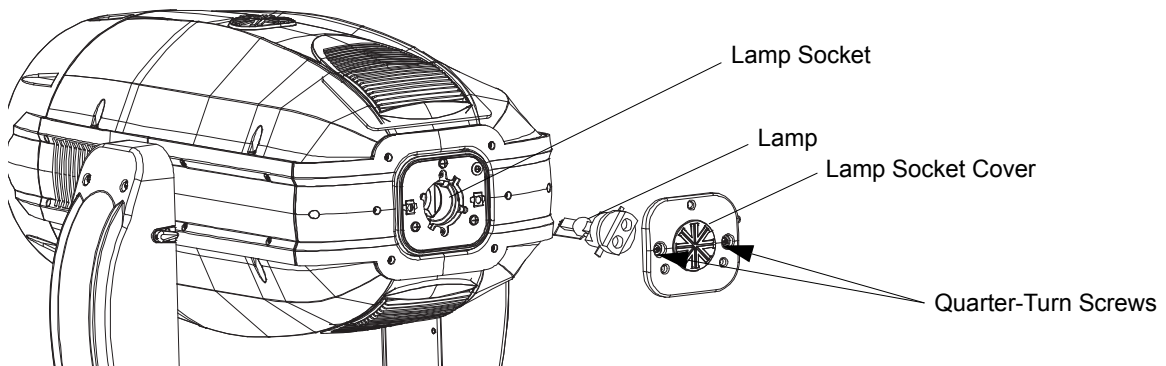

Figure 2-2: Lamp Socket Cover Removal

Step 6. As shown in [Figure 2-3](#), align lamp tabs with lamp socket.

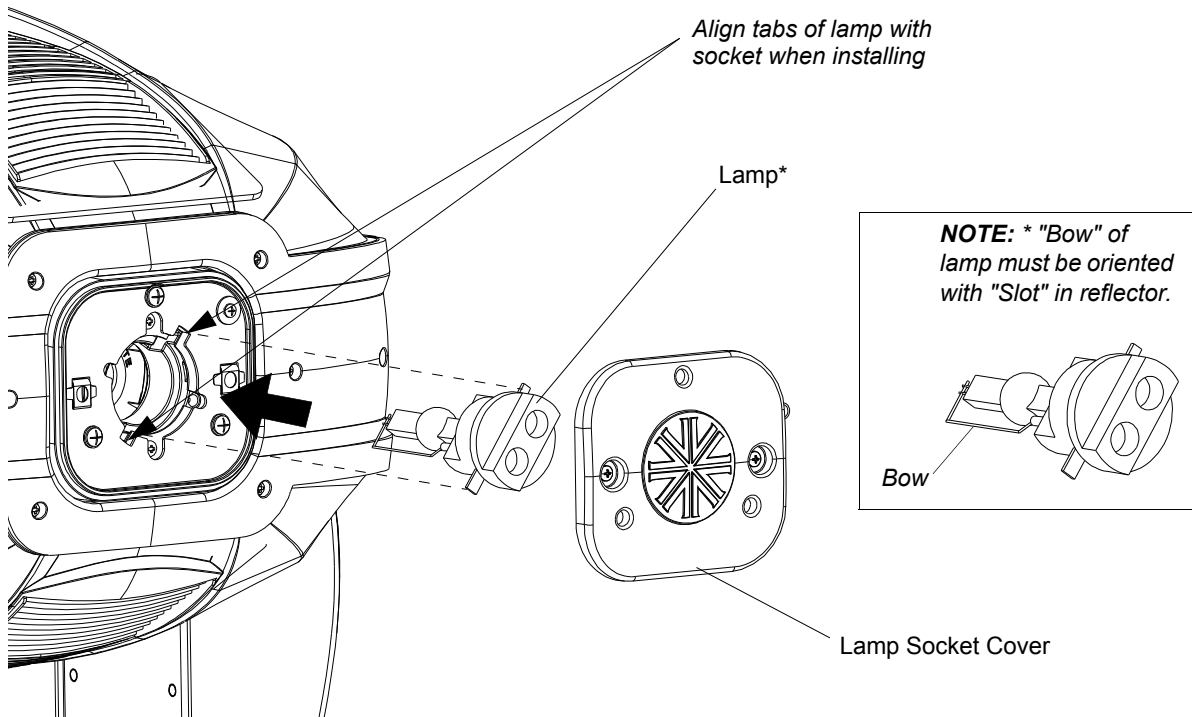

Figure 2-3: Lamp Installation

Step 7. Install lamp fully into lamp socket, taking care not to touch lamp glass.

Step 8. Turn lamp clockwise to seat lamp into socket. Lamp base should be aligned as illustrated in [Figure 2-4](#).

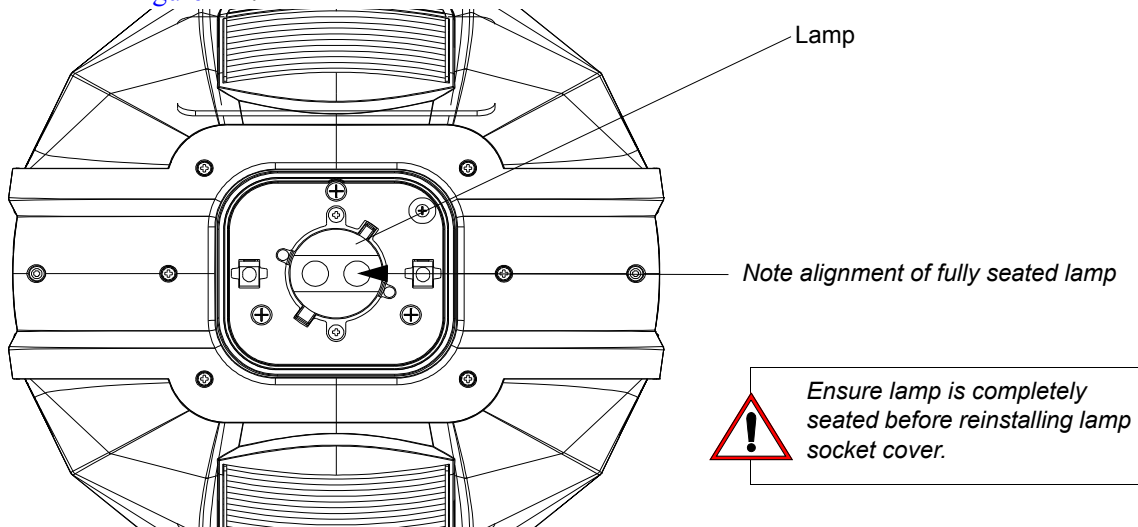

Figure 2-4: Installed Lamp

Step 9. Reinstall lamp socket cover. Make sure safety tether is completely encapsulated within lamp socket cover.

Step 10. Disengage tilt lock to allow luminaire head to move freely.

Step 11. Align lamp as described in "[Align Lamp For Maximum Beam Irradiance](#)" on page 19.

Align Lamp For Maximum Beam Irradiance

After a new lamp is installed in the luminaire, it will be necessary to align the lamp to optimize the beam.



WARNING: Backcap and alignment screws will be HOT during lamp operation. Wear gloves and/or use tools to prevent burns.

To align lamp:

- Step 1. Set intensity to 100%.
- Step 2. Position beam on a white wall at a distance of 10 to 20 feet.
- Step 3. If wash lens is in beam, use console or internal luminaire menu controls to remove. Set zoom to zero and focus to a hard edge. Be sure that beam-size iris completely opened.
- Step 4. Using three alignment screws (as indicated with Red Arrows in [Figure 2-5](#)) adjust hot spot to center of beam.
- Step 5. Check color uniformity as follows:
 - a. Position one of the color (cyan or magenta works best) at 65% of maximum.
 - b. Verify that beam color is uniform (if lamp is misaligned, color will be concentrated to one side of beam). If color is not uniform, readjust lamp using lamp alignment screws until color is uniform across entire beam field.

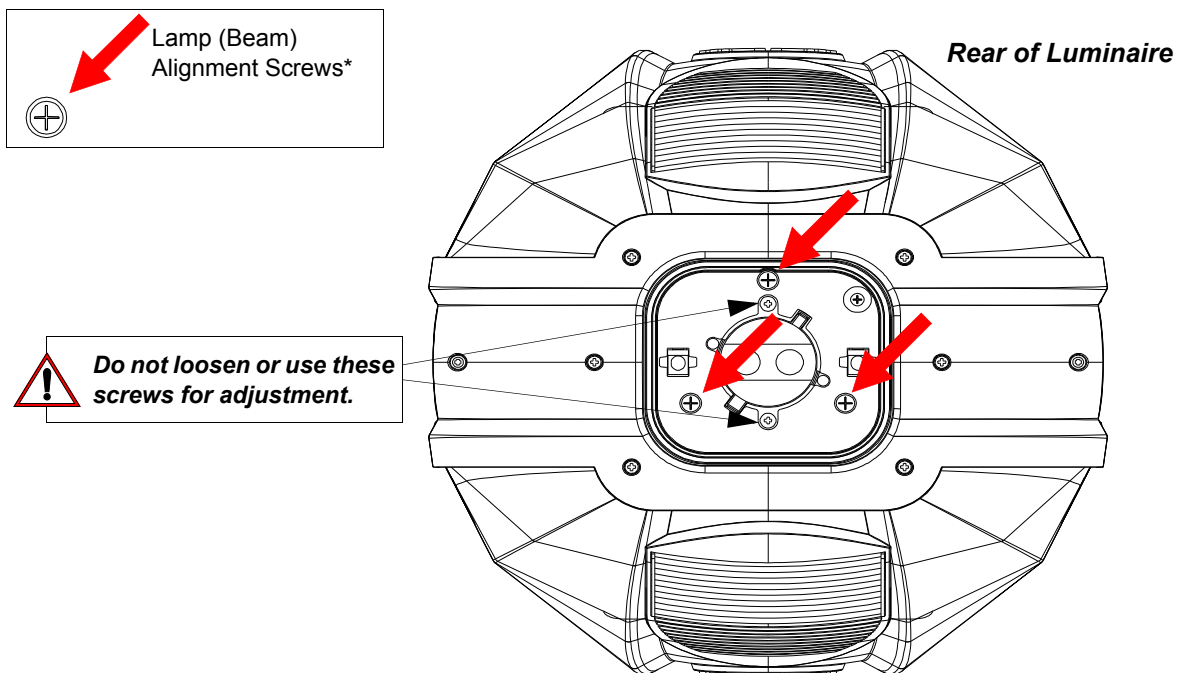

NOTE: *Lamp Socket Cover removed for clarity. It is not necessary to remove Lamp Socket Cover to align lamp.

Figure 2-5: Lamp Alignment Screws

Hanging the Luminaire

The VL4000 BeamWash Luminaire can be hung horizontally or vertically from any structure designed to work with the type of load created by this moving luminaire. Two mounting truss hooks or other mounting hardware are required. Many compatible truss hooks are available from different manufacturers for your particular needs.

A minimum of two hooks per luminaire is required. If mounting method does not use truss hooks, two attachment points, per luminaire, are required.

Install mounting hardware and brackets:

- Step 1. Install truss hooks (also refer to “[Truss Hook Hardware \(by others\)](#)” on page 20) for additional information) on two provided truss hook brackets as required as shown in [Figure 2-6](#).

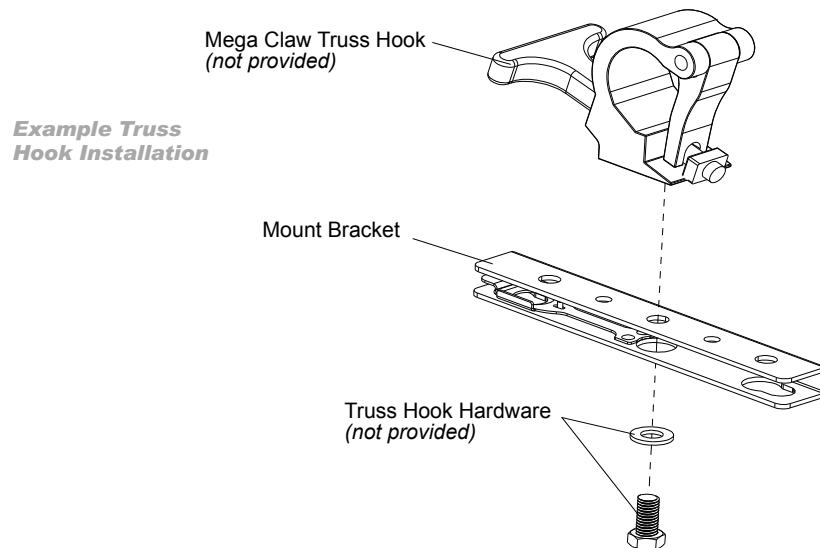

Figure 2-6: Truss Hook Installation

Note: Various types of truss hooks can be used. The Mega Claw truss hook (as shown in the example above) as well as many other standard hooks, can be ordered separately.

Truss Hook Hardware (by others)

When installing hanging hooks on mounting brackets, Vari-Lite strongly recommends the use of a Belleville washer (*by others*, [Figure 2-7](#) shows examples) when installing a truss hook or claw as shown in [Figure 2-6](#).

The Belleville washer's size should be approximately 0.505-inch (inner diameter) by 1.00-inch (outer diameter). Belleville washers are available in various



Figure 2-7: Belleville Washer Examples

thicknesses and any of the following thicknesses (0.035-inch, 0.043-inch, 0.050-inch, 0.073-inch) are acceptable for the application described herein.

The washer serves two purposes:

- To spread out the load. When a washer IS NOT used, the bolt head (*without a washer*) concentrates the load in a smaller area, creating focused stress on the steel bracket, making premature failure possible. A steel washer is recommended to spread this load over a larger surface area.
- To keep the bolt in place. The recommended Belleville washer maintains tension in the bolted assembly and prevents it from vibrating loose.

If a Belleville washer is not available, a regular flat washer measuring in diameter of 1 inch (minimum) can be used in conjunction with a suitable split lock washer situated between the bolt head and flat washer.

- Step 2. Determine required configuration of bracket installation. Brackets may be installed in many different orientations as shown in [Figure 2-8](#) on [page 22](#).
- Step 3. While pulling up on locking mechanism release, fit keyed holes onto raised mounting buttons at bottom of enclosure. Slide forward and release locking mechanism to lock in place. Ensure brackets are locked securely.



WARNING: Ensure that the bracket locking mechanism is fully seated after the bracket is installed on the luminaire. **AVERTISSEMENT:** Assurez-vous que le mécanisme de support de verrouillage est complètement inséré après le support est installé sur l'appareil.

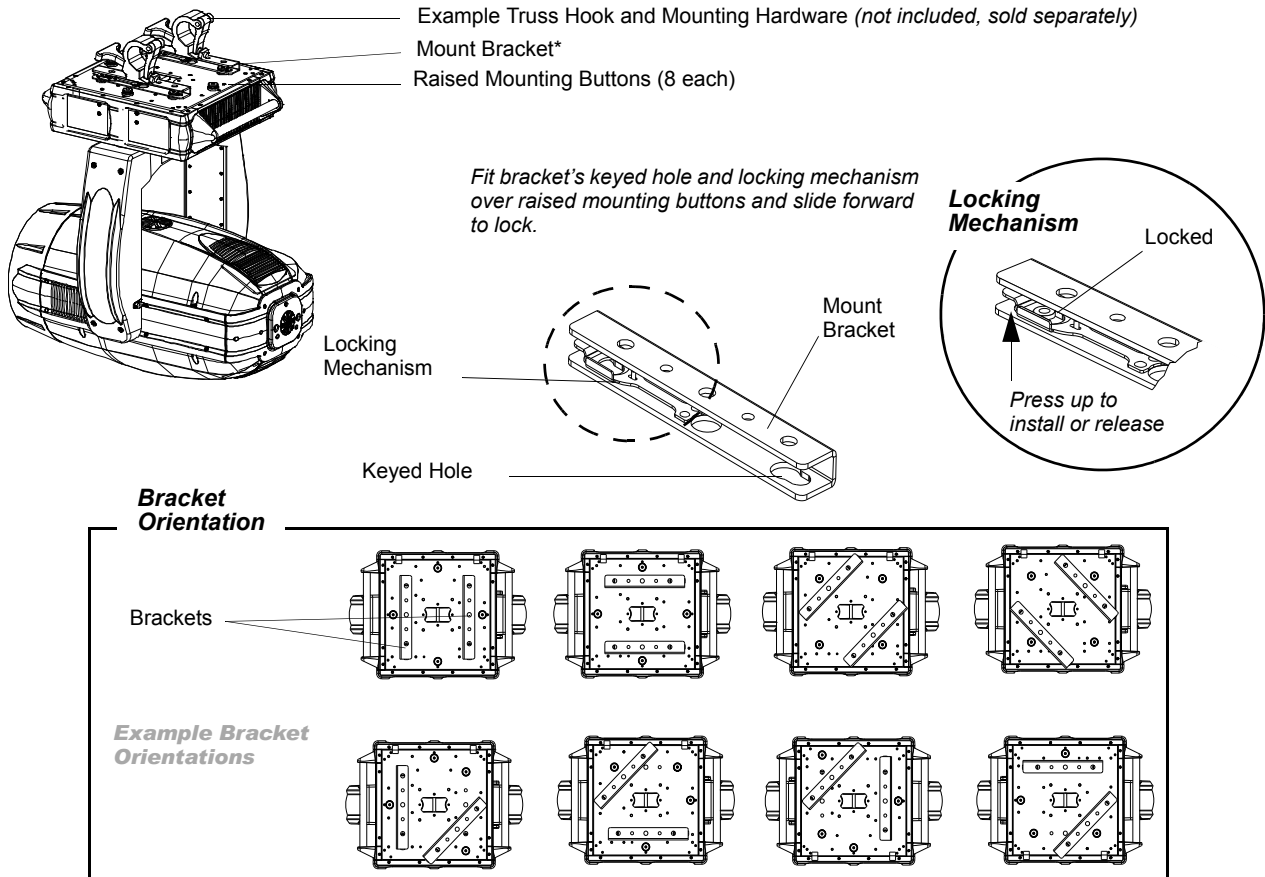

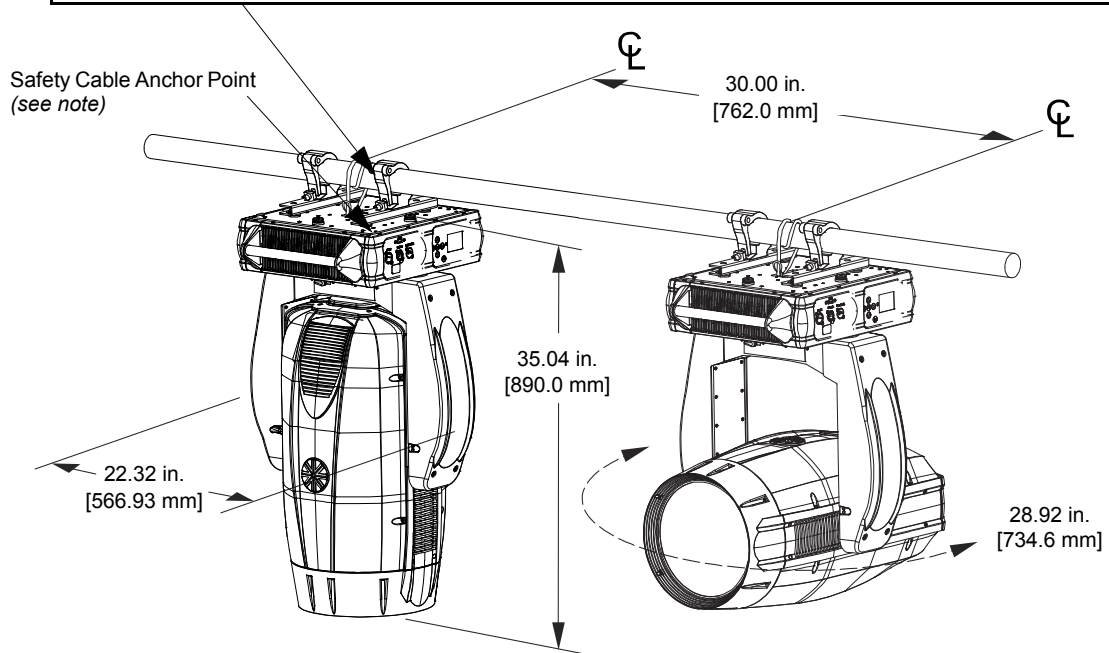

Figure 2-8: Installing Brackets on Luminaire Enclosure

Installing in Truss:

- Step 1. Using two people, lift luminaire into mounting position.
- Step 2. Secure in place with truss hook. Ensure truss hook hardware that locks hook in place (e.g. wing bolt) is properly tightened and that luminaire is fully supported.
- Step 3. Attach safety cable (as required) as follows (refer to [Figure 2-9](#) on [page 23](#)):
 - a. Loop safety cable at least once around safety cable anchor point rod.
 - b. Loop safety cable at least once around truss/pipe and secure around pipe.

 **Safety Cable:** Recommended for hanging installations. May be required by local codes. Safety cable is sold separately.
Câble de sécurité: Recommandé pour les installations pendaison. Peut être exigé par les codes locaux. Câble de sécurité est vendu séparément.



Note, truss hooks shown are sold separately. Truss and pipe by others.

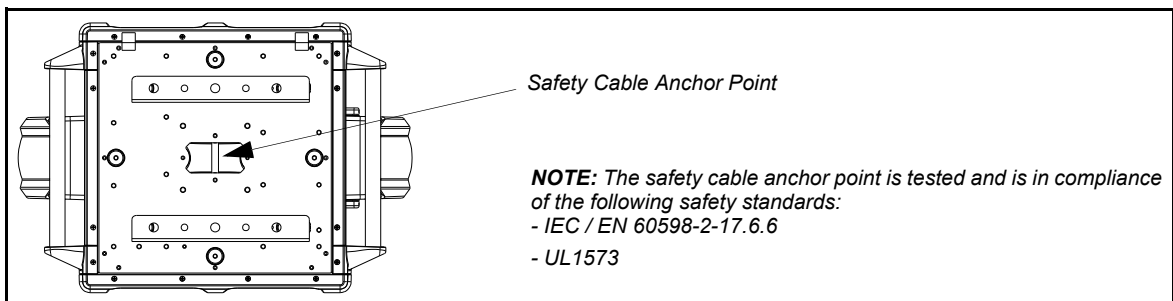

Figure 2-9: Safety Cable Installation / Luminaire Hanging

- Step 4. Make sure tilt and pan locks are disengaged so luminaire moves freely.
- Step 5. Connect power and data cables according to procedure given in [“Connecting Data and Power” on page 24.](#)

Floor Mounting the Luminaire

All luminaires included in this manual are designed to sit directly on its base in a floor installation application. When used in this type of application, be sure to leave enough space around the luminaire to allow proper, uninterrupted airflow for cooling and movement.

Connecting Data and Power

A maximum of 32 luminaires may be connected in any one DMX data link.

Note: This maximum limit applies to the luminaire "daisy chain" only. Your system or console may require fewer luminaires on a single data link path. Consult your console documentation for more information.

To connect power and data:

- Step 1. Connect data cable from console to first luminaire in chain at DATA IN connector.
- Step 2. If required, connect additional data cables from DATA THRU connectors to DATA IN connectors of remaining luminaires in link.
- Step 3. At last luminaire in link, install male termination connector at DATA THRU connector. (Luminaires and other devices on the same DMX chain may not function properly without termination.)

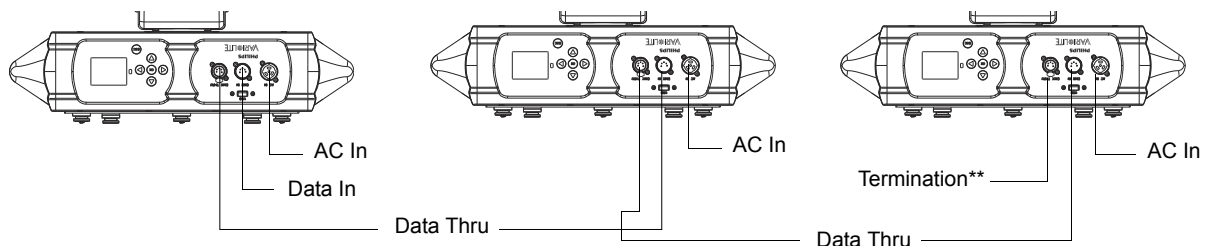

| VL4000 BeamWash Luminaire Channel Requirements* | | |
|---|---|--------------|
| DMX512 Channels | Description | Menu Display |
| 46 Channels | Enhanced 16-Bit Mode (<i>default</i>) | 16E |
| 41 Channels | 16-Bit Mode | 16 |

**As set by the luminaire's menu system.*

****DMX terminator required for last fixture on DMX line.**

Figure 2-10: Data Link

- Step 4. Connect AC Input Cable connector to power input source.
- Step 5. Dress AC input and data cables and secure them so that they will not interfere with luminaire head and yoke movement.

Powering Up

Power-Up Procedure

When the luminaire is powered up for the first time, the default setting is enabled and the lamp will remain off. When AC power is applied, the luminaire will immediately begin a calibration sequence that steps it through full pan and tilt movements. The internal color and beam mechanisms will also move through a full range of motion. After calibration, the luminaire head will either stop at its "home" position (which positions the pan axis at mid-rotation and the head parallel to the yoke with the lens pointing away from the luminaire enclosure) or move to its current DMX-defined position if DMX data is present. All internal mechanisms also move to their "home" or DMX-defined positions.



CAUTION: Before applying power, be sure the luminaire is hung (or positioned), and the pan and tilt locks are disengaged, so that the head and yoke can move freely without restriction.

To power up:

- Step 1. At each luminaire, apply power connecting the power cable to the unit.
- Step 2. Luminaire will automatically step through calibration and stop at "home" position (only if DMX is not present).

Addressing

Program Starting Address

The address setting for DMX console controlled systems is entered using the Menu Display (refer to “Menu Operation” on page 64). The luminaire retains the DMX address even if power is removed.

Note: Refer to your console operating instructions for specific information regarding its addressing requirements.

DMX Address

To set, edit, and save a DMX address:

- Step 1. Press [ESC].
 - Step 2. Press [Up] / [Down] arrows until **Address** appears. Press [OK].
 - Step 3. Use [Left] and [Right] arrow buttons to scroll through all digits.
 - Step 4. Once at desired digit, use [Up] and [Down] arrows to change highlighted digit.
 - Step 5. Once digit is set, use [Left] and [Right] arrow buttons to set other digits in DMX address.
 - Step 6. Once all digits are set in DMX address, press [OK] to set.
 - Step 7. DMX will display and is saved.
-

Program Starting Address Without Calibrating Luminaire

It is possible to bypass the calibration sequence and go directly to the Menu Display programming in order to pre-program an address setting.

Program starting address without calibrating luminaire:

- While powering up luminaire, press and hold [ESC].
 - When display changes from "Starting" to the DMX address, program address as in [Program Starting Address](#) above.
-



Note: The luminaire will require a reset to restore control.

Program starting address in Battery Mode:

- To activate menu in Battery Mode when the fixture is not connected to a power source, press [OK] and [ESC] together. The LCD screen will come on. Address the fixture as described above. The LCD screen will shut off after one minute of inactivity.

Transporting

Overview

When shipping or transporting VARI*LITE Luminaires, Vari-Lite recommends that the luminaire(s) be sufficiently protected against any (including, but not limited to) shock, vibration, drops, jarring, exposure to the environment, etc.

Failure to sufficiently protect any VARI*LITE luminaire during shipping or transportation will result in damage and void the luminaire's warranty. Vari-Lite will not be responsible for any shipping damage or breakage of any product under any circumstances. Vari-Lite will not be responsible for any third party case manufacturer's cases.



Note: As with all automated luminaires, proper handling and suitable protective shipping cases should be used when transporting fixtures to reduce the risk of damage. For more information, please refer to Vari-Lite technical notice (TN-235) "Transportation and Shipping Case Requirements" in the "Support" area of the Vari-Lite web site.

Transportation and Shipping Case Requirements

Cases to transport VARI*LITE luminaires should meet the following loading requirements:

- Luminaire head, yoke, and enclosure sub-assemblies shall be equally supported and constrained where no one sub-assembly (head, yoke, or enclosure) fully supports the entire mass of the luminaire.
- The interior of the case shall be of high quality and uniform density foam. The foam shall be of the same type and density throughout as to equally and uniformly support loading at every contact surface.
- The case shall, when laid on any of its six (6) surfaces, maintain the loading requirements outlined above.
- All cases not meeting the aforementioned loading requirements, with wheels, shall have markings on the exterior of the case that the unit is to be transported on it wheels only (e.g. "Case must be transported and remain [at all times] on its wheels").

Notes

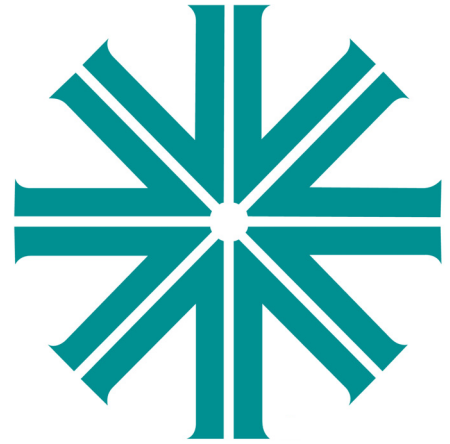

CHAPTER 3.

Operation

This chapter contains instructions for operating the luminaire using DMX control and for updating the internal software.

- **Color Control and Gobos**
- **DMX Operation**
- **Luminaire Timing**
- **RDM Parameter IDs**
- **Updating Software**

Color Control and Gobos

The following is a brief description of each color control and gobo projection capabilities.

Color Mixing

The VL4000 BeamWash Luminaire provides full CYM color cross-fading and two fixed color wheels.

- The CYM color system offers a three filter CYM cross fading system capable of extremely smooth movements at both slow and fast speeds, and a variable CTO color temperature correction system.
- Each fixed color wheel holds 5 fixed colors for rich color projection and snap color changes. The two fixed color wheels are opposing wheels. Each wheel features five interchangeable color filters that are capable of producing multi-color effects and variable wheel rotations.

Fixed Color Wheel 1

Fixed Color Wheel 1 holds five color filters and has one open space as illustrated in [Figure 3-1](#). Note, the open space will not accommodate a filter.

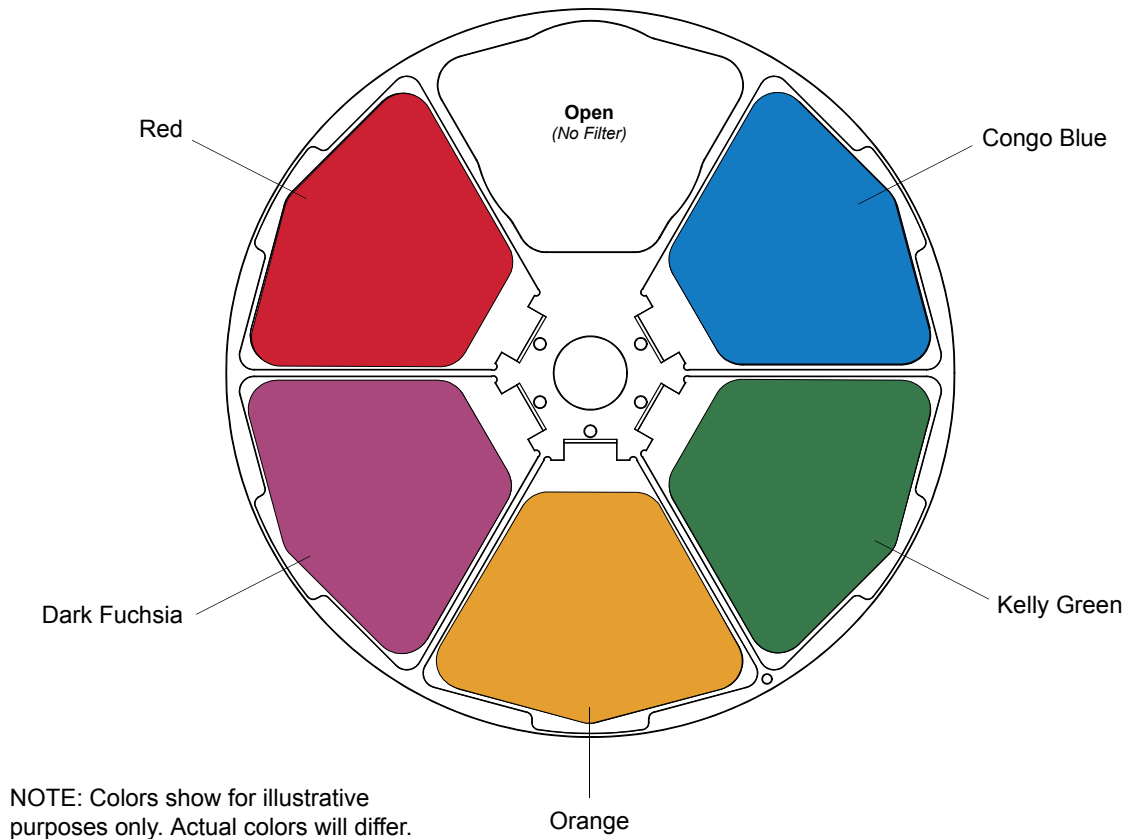

Figure 3-1: VL4000 BeamWash Fixed Color Wheel 1

Fixed Color Wheel 2

Fixed Color Wheel 2 holds five color filters and has one open space as illustrated in [Figure 3-2](#). Note, the open space will not accommodate a filter.

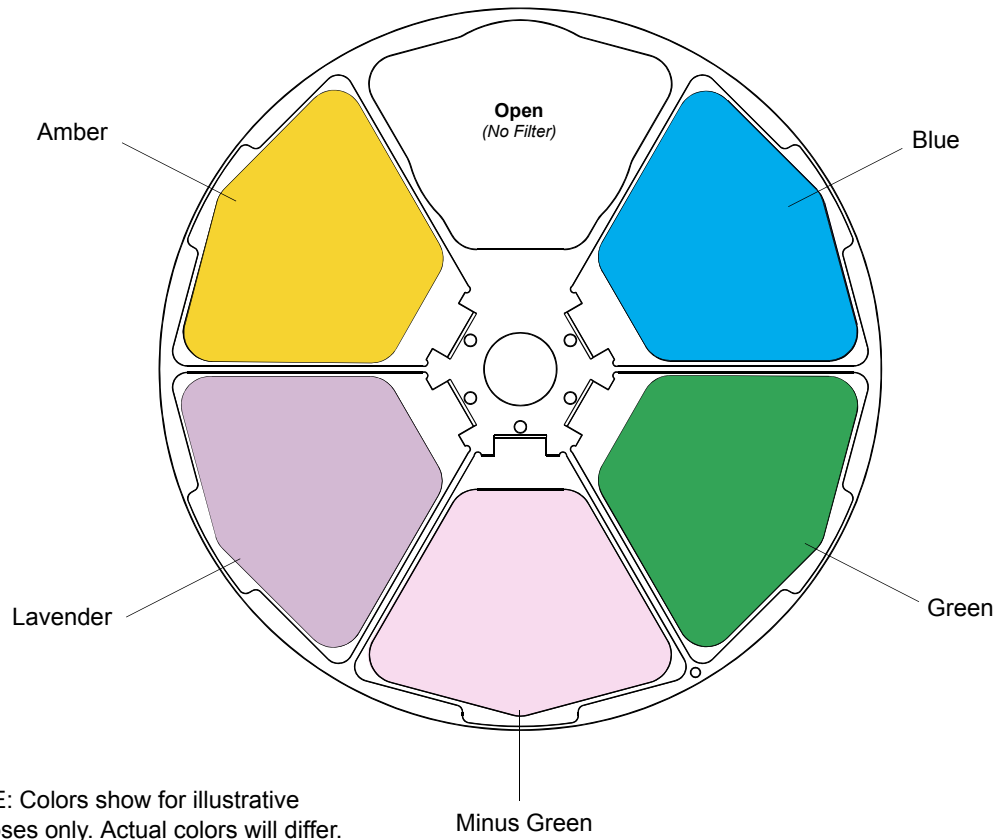

Figure 3-2: VL4000 BeamWash Fixed Color Wheel 2

Gobos

Each luminaire contains two rotating gobo wheels. Each rotating gobo wheel offers seven rotatable, indexable gobo positions and one open position.



CAUTION: VL4000 BeamWash Luminaires accept glass gobos only. Use of metal gobos in these luminaires may damage gobo assembly and will void the luminaire warranty.

Note: For all available patterns and their associated numbers, refer to VARI*IMAGE System page on the Vari-Lite web site or contact your local regional sales manager or Authorized VARI*LITE Dealer.

Rotating Gobo Wheel 1

Standard load rotating gobos for Rotating Gobo Wheel 1 are shown in [Figure 3-3](#) and described in [Table 1](#), “Rotating Gobo Wheel 1 - Standard Effects and Positions”.

Table 1: Rotating Gobo Wheel 1 - Standard Effects and Positions

| Position | Gobo | Gobo Part Number |
|----------|-------------------|------------------|
| 0 (Open) | None | None |
| 1 | Stacked Ovals | 41.9704.6010 |
| 2 | Chopped | 41.9704.4428 |
| 3 | Sliced | 41.9704.4429 |
| 4 | Night Sky | 41.9704.5011 |
| 5 | Blades | 41.9704.4430 |
| 6 | Psyclone | 41.9704.4431 |
| 7 | Circle of Holes 1 | 41.9704.6004 |

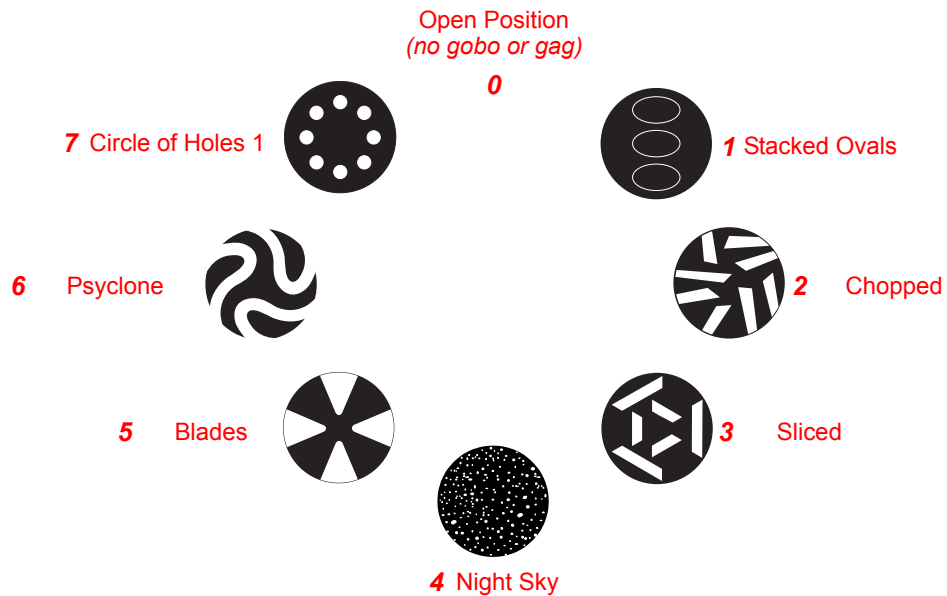

Figure 3-3: Rotating Gobo Wheel 1 - Standard Gobo Load

Rotating Gobo Wheel 2

Standard load rotating gobos for Rotating Gobo Wheel 2 are shown in Figure 3-4 and described in Table 2, “Rotating Gobo Wheel 2 - Standard Effects and Positions,” on page 33.

Table 2: Rotating Gobo Wheel 2 - Standard Effects and Positions

| Position | Gobo | Gobo Part Number |
|----------|------------------|------------------|
| 0 (Open) | None | None |
| 1 | Circle of Eights | 41.9704.4411 |
| 2 | Punch Card | 41.9704.4412 |
| 3 | Vertical Bars | 41.9704.4413 |
| 4 | Lattice | 41.9704.4414 |
| 5 | Wavy Triangle | 41.9704.4415 |
| 6 | Dot Buffet | 41.9704.4416 |
| 7 | Quadcone, Red | 41.9704.4291 |

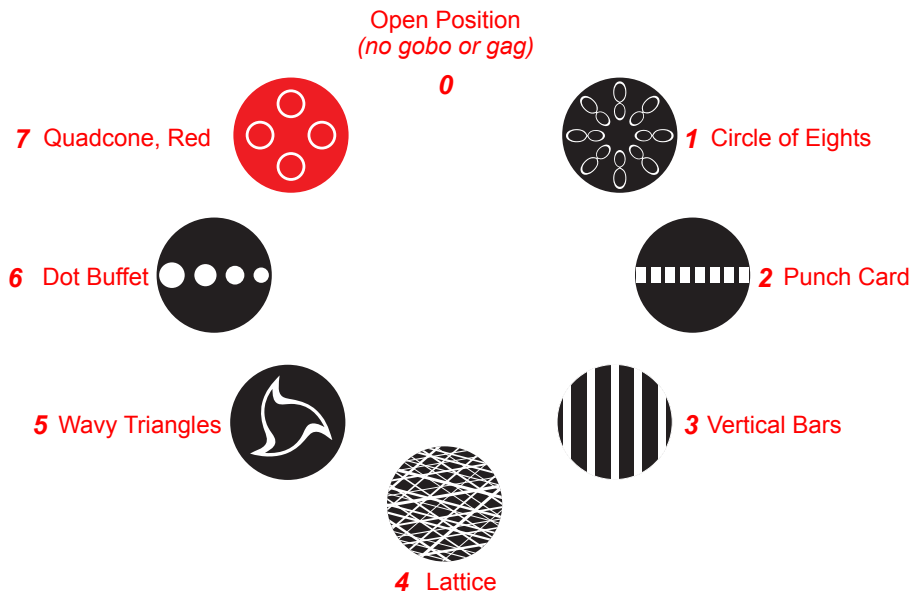

Figure 3-4: Rotating Gobo Wheel 2 - Standard Gobo Load

Animation Wheel

The VL4000 BeamWash Luminaire has one animation wheel which is rotatable and offers variable motion control from horizontal to vertical.

Animation Wheel - Concurrent

[Figure 3-5](#) shows the VL4000 BeamWash Luminaire Animation Wheel.

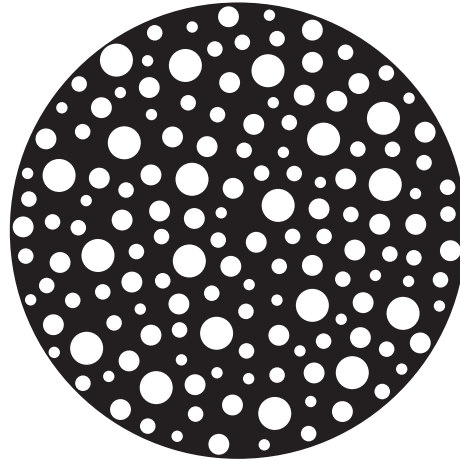

Figure 3-5: Animation Wheel - Concurrent

DMX Operation

VL4000 BeamWash Channel Mapping

These tables assume a DMX start address of 1. When a different starting address is used, this address becomes channel 1 function and other functions follow in sequence. This section contains the DMX channel maps for the VL4000 BeamWash Luminaire. Users can select one of two maps as detailed in these sections:

- “Enhanced 16-Bit Channel Mapping (Default)” (starting below)
- “16-Bit Channel Mapping” on page 40.

Enhanced 16-Bit Channel Mapping (Default)

Table 3 provides DMX channel mapping of the DMX512 control values when the VL4000 BeamWash Luminaire is in Enhanced 16-Bit DMX mode (as set by the luminaire’s menu system).

Table 3: VL4000 BeamWash Enhanced 16-Bit DMX Channel Mapping

| DMX Channel | Parameters | Range (DMX) | Range (%) | Default Value* | Description / Operation |
|-------------|---------------------|-------------|-----------|----------------|---|
| 1 | Intensity | 0 - 255 | 0 - 100% | 0 | 8-bit control of Fixture Intensity from 0 - 100% |
| 2 | Pan High Byte | 0 - 65535 | 0 - 100% | 32767 | 16-bit linear control of pan from 0° to 520°. |
| 3 | Pan Low Byte | | | | |
| 4 | Tilt High Byte | 0 - 65535 | 0 - 100% | 32767 | 16-bit linear control of tilt from 0° to 270°. |
| 5 | Tilt Low Byte | | | | |
| 6 | Edge High Byte | 0 - 65535 | 0 - 100% | 0 | 16-bit linear control of edge functions. |
| 7 | Edge Low Byte | | | | |
| 8 | Zoom High Byte | 0 - 65535 | 0 - 100% | 0 | 16-bit linear control of fixture zoom range between 0 (4 degrees) to 65535 (60 Degrees). |
| 9 | Zoom Low Byte | | | | |
| 10 | Optic Style | 0 - 255 | 0 - 100% | 0 | Toggles optical ability between Wash, Beam, and Shaft. 0 - 127 = Wash Optics 128 - 191 = Beam Optics 192 - 255 = Shaft Optics |
| 11 | Cyan | 0 - 255 | 0 - 100% | 0 | Controls Cyan color mechanism. |
| 12 | Yellow | 0 - 255 | 0 - 100% | 0 | Controls Yellow color mechanism. |
| 13 | Magenta | 0 - 255 | 0 - 100% | 0 | Controls Magenta color mechanism. |
| 14 | CTO | 0 - 255 | 0 - 100% | 0 | Controls CTO mechanism. |
| 15 | Fixed Color Wheel 1 | 0 - 255 | 0 - 100% | 0 | 8-bit control of Color Wheel 1. See Channel 16 for options. 0 - 23 = OPEN 24 - 69 = RED (Center at DMX 46) 70 - 116 = DARK FUCHSIA (Center at DMX 93) 117 - 162 = ORANGE (Center at DMX 139) 163 - 209 = KELLY GREEN (Center at DMX 186) 210 - 255 = CONGO BLUE (Center at DMX 232) |

Table 3: VL4000 BeamWash Enhanced 16-Bit DMX Channel Mapping

| DMX Channel | Parameters | Range (DMX) | Range (%) | Default Value* | Description / Operation |
|-------------|---|-------------|-----------|----------------|--|
| 16 | Fixed Color Wheel 1 Control | 0 - 255 | 0 - 100% | 0 | Used as a control channel for different movement options of Color Wheel 1. 0 - 5 = Linear Movement using shortest (quickest) path. 6 - 10 = Linear Movement using normal (longest) path. 11 - 15 = Wheel Spin Forward (Fast to Slow) 16 - 20 = Wheel Spin STOP 21 - 25 = Wheel Spin Reverse (Slow to Fast) 26 - 56 = Color Shake Quickest Path (Slow to Fast) 57 - 87 = Color Shake Normal Path (Slow to Fast) 88 - 255 = <i>Reserved Values</i> |
| 17 | Fixed Color Wheel 2 | 0 - 255 | 0 - 100% | 0 | 8-bit control of Color Wheel 2. See Channel 18 for options. 0 - 23 = OPEN 24 - 69 = BLUE (Center at DMX 46) 70 - 116 = GREEN (Center at DMX 93) 117 - 162 = MINUS GREEN (Center at DMX 139) 163 - 209 = LAVENDER (Center at DMX 186) 210 - 255 = AMBER (Center at DMX 232) |
| 18 | Fixed Color Wheel 2 Control | 0 - 255 | 0 - 100% | 0 | Used as a control channel for different movement options of Color Wheel 2. 0 - 5 = Linear Movement using shortest (quickest) path. 6 - 10 = Linear Movement using normal (longest) path. 11 - 15 = Wheel Spin Forward (Fast to Slow) 16 - 20 = Wheel Spin STOP 21 - 25 = Wheel Spin Reverse (Slow to Fast) 26 - 56 = Color Shake Quickest Path (Slow to Fast) 57 - 87 = Color Shake Normal Path (Slow to Fast) 88 - 255 = <i>Reserved Values</i> |
| 19 | Gobo Wheel 1 | 0 - 255 | 0 - 100% | 0 | 8-bit control of Gobo Wheel 1. See Channel 22 for control options. 0 - 5 = Open - No Gobo 6 - 10 = Gobo 1 (Stacked Ovals) Index 11 - 15 = Gobo 2 (Chopped) Index 16 - 20 = Gobo 3 (Triple Stack) Index 21 - 25 = Gobo 4 (Night Sky) Index 26 - 30 = Gobo 5 (Blades) Index 31 - 35 = Gobo 6 (Psychlone) Index 36 - 40 = Gobo 7 (Circle of Holes 1) Index 41 - 45 = Open - No Gobo 46 - 50 = Gobo 1 (Stacked Ovals) Rotate 51 - 55 = Gobo 2 (Chopped) Rotate 56 - 60 = Gobo 3 (Triple Stack) Rotate 61 - 65 = Gobo 4 (Night Sky) Rotate 66 - 70 = Gobo 5 (Blades) Rotate 71 - 75 = Gobo 6 (Psychlone) Rotate 76 - 80 = Gobo 7 (Circle of Holes 1) Rotate 81 - 85 = Open - No Gobo 86 - 90 = Gobo 1 Gobo 1 (Stacked Ovals) Rotate with Mega Stepping 91 - 95 = Gobo 2 (Chopped) Rotate with Mega Stepping 96 - 100 = Gobo 3 (Triple Stack) Rotate with Mega Stepping 101 - 105 = Gobo 4 (Night Sky) Rotate with Mega Stepping 106 - 110 = Gobo 5 (Blades) Rotate with Mega Stepping 111 - 115 = Gobo 6 (Psychlone) Rotate with Mega Stepping 116 - 120 = Gobo 7 (Circle of Holes 1) Rotate with Mega Stepping 121 - 255 = <i>Reserved Values</i> |
| 20 | Gobo Wheel 1 Index / Rotate - High Byte | 0 - 65535 | 0 - 100% | 32767 | 16 bit control of Gobo Wheel 1 index and rotation. |
| 21 | Gobo Wheel 1 Index / Rotate - Low Byte | | | | Rotate Fast to Slow <<< = DMX 0 - 32756 Rotate STOP = DMX 32757 - 32780 Rotate Slow to Fast >>> = DMX 32781 - 65535 |

Table 3: VL4000 BeamWash Enhanced 16-Bit DMX Channel Mapping

| DMX Channel | Parameters | Range (DMX) | Range (%) | Default Value* | Description / Operation |
|-------------|---|-------------|-----------|----------------|--|
| 22 | Gobo Wheel 1 Control | 0 - 255 | 0 - 100% | 0 | Used as a control channel for different movement options for Gobo Wheel 1 (Channel 19). 0 - 5 = Gobo Selection using shortest (quickest) path. 6 - 10 = Gobo Selection using normal (longest) path. 11 - 20 = <i>Reserved Values</i> 21 - 50 = Wheel Spin Forward (Fast to Slow) 51 - 60 = Wheel Spin STOP 61 - 90 = Wheel Spin Reverse (Slow to Fast) 91 - 120 = Gobo Shake Quickest Path (Slow to Fast) 121 - 150 = Gobo Shake Normal Path (Slow to Fast) 151 - 180 = Gobo Twist Quickest Path (Slow to Fast) 181 - 210 = Gobo Twist Normal Path (Slow to Fast) 211 - 255 = <i>Reserved Values</i> |
| 23 | Gobo Wheel 2 | 0 - 255 | 0 - 100% | 0 | 8-bit control of Gobo Wheel 2. See Channel 26 for control options. 0 - 5 = Open - No Gobo 6 - 10 = Gobo 1 (Circle of Eights) Index 11 - 15 = Gobo 2 (Punch Card) Index 16 - 20 = Gobo 3 (Vertical Bars) Index 21 - 25 = Gobo 4 (Lattice) Index 26 - 30 = Gobo 5 (Wavy Triangle) Index 31 - 35 = Gobo 6 (Dot Buffet) Index 36 - 40 = Gobo 7 (Quadcone Red) Index 41 - 45 = Open - No Gobo 46 - 50 = Gobo 1 (Circle of Eights) Rotate 51 - 55 = Gobo 2 (Punch Card) Rotate 56 - 60 = Gobo 3 (Vertical Bars) Rotate 61 - 65 = Gobo 4 (Lattice) Rotate 66 - 70 = Gobo 5 (Wavy Triangle) Rotate 71 - 75 = Gobo 6 (Dot Buffet) Rotate 76 - 80 = Gobo 7 (Quadcone Red) Rotate 81 - 85 = Open - No Gobo 86 - 90 = Gobo 1 (Circle of Eights) Rotate with Mega Stepping 91 - 95 = Gobo 2 (Punch Card) Rotate with Mega Stepping 96 - 10 = Gobo 3 (Vertical Bars) Rotate with Mega Stepping 101 - 105 = Gobo 4 (Lattice) Rotate with Mega Stepping 106 - 110 = Gobo 5 (Wavy Triangle) Rotate with Mega Stepping 111 - 115 = Gobo 6 (Dot Buffet) Rotate with Mega Stepping 116 - 120 = Gobo 7 (Quadcone Red) Rotate with Mega Stepping 121 - 255 = <i>Reserved Values</i> |
| 24 | Gobo Wheel 2 Index / Rotate - High Byte | 0 - 65535 | 0 - 100% | 32767 | 16 bit control of Gobo Wheel 2 index and rotation. |
| 25 | Gobo Wheel 2 Index / Rotate - Low Byte | | | | Rotate Fast to Slow <<< = DMX 0 - 32756 Rotate STOP = DMX 32757 - 32780 Rotate Slow to Fast >>> = DMX 32781 - 65535 |
| 26 | Gobo Wheel 2 Control | 0 - 255 | 0 - 100% | 0 | Used as a control channel for different movement options for Gobo Wheel 2 (Channel 23). 0 - 5 = Gobo Selection using shortest (quickest) path. 6 - 10 = Gobo Selection using normal (longest) path. 11 - 20 = <i>Reserved Values</i> 21 - 50 = Wheel Spin Forward (Fast to Slow) 51 - 60 = Wheel Spin STOP 61 - 90 = Wheel Spin Reverse (Slow to Fast) 91 - 120 = Gobo Shake Quickest Path (Slow to Fast) 121 - 150 = Gobo Shake Normal Path (Slow to Fast) 151 - 180 = Gobo Twist Quickest Path (Slow to Fast) 181 - 210 = Gobo Twist Normal Path (Slow to Fast) 211 - 255 = <i>Reserved Values</i> |
| 27 | Animation Wheel (Concurrent) | 0 - 255 | 0 - 100% | 0 | Controls Animation Wheel linearly within the beam. |

Table 3: VL4000 BeamWash Enhanced 16-Bit DMX Channel Mapping

| DMX Channel | Parameters | Range (DMX) | Range (%) | Default Value* | Description / Operation |
|-------------|---|-------------|-----------|----------------|--|
| 28 | Animation Wheel (Concurrent) Index / Rotate - High Byte | 0 - 65535 | 0 - 100% | 32767 | 16 bit control of the Animation Wheel 1 index and rotation. |
| 29 | Animation Wheel (Concurrent) Index / Rotate - Low Byte | | | | Rotate Fast to Slow <<< = DMX 0 - 32756 Rotate STOP = DMX 32757 - 32780 Rotate Slow to Fast >>> = DMX 32781 - 65535 |
| 30 | Animation Wheel (Concurrent) Control | 0 - 255 | 0 - 100% | 0 | Used as a control channel for Animation Wheel 1. 0 - 5 = Index using shortest (quickest) path. 6 - 10 = Index using normal (longest) path. 11 - 15 = Rotate Normal 16 - 20 = Rotate with Mega Stepping 21 - 25 = Reserved Values 26 - 56 = Image Shake using shortest (quickest) path slow to fast. 57 - 87 = Image Shake using normal (longest) path slow to fast. 88 - 255 = Reserved Values |
| 31 | Iris | 0 - 255 | 0 - 100% | 0 | Controls Iris mechanism from 0 (open) to 255 (full). |
| 32 | Beam Shaping | 0 - 255 | 0 - 100% | 0 | Controls Beam Shaping mechanism with following values. 0 - 5 = Open (Hybrid Zoom Range) 6 - 10 = Index (Hybrid Zoom Range) 11 - 15 = Rotate Normal (Hybrid Zoom Range) 16 - 20 = Rotate with Mega Stepping (Hybrid Zoom Range) 21 - 25 = Open (Narrow Zoom Range) 26 - 30 = Index (Narrow Zoom Range) 31 - 35 = Rotate Normal (Narrow Zoom Range) 36 - 40 = Rotate with Mega Stepping (Narrow Zoom Range) 41 - 45 = Open (Wide Zoom Range) 46 - 50 = Index (Wide Zoom Range) 51 - 55 = Rotate Normal (Wide Zoom Range) 56 - 60 = Rotate with Mega Stepping (Wide Zoom Range) 61 - 255 = Reserved Values |
| 33 | Beam Shaping Index / Rotate - High Byte | 0 - 65535 | 0 - 100% | 32767 | 16 bit control of Beam Shaping rotation and index. |
| 34 | Beam Shaping Index / Rotate - Low Byte | | | | Rotate Fast to Slow <<< = DMX 0 - 32756 Rotate STOP = DMX 32757 - 32780 Rotate Slow to Fast >>> = DMX 32781 - 65535 |
| 35 | Prism | 0 - 255 | 0 - 100% | 0 | Controls Prism mechanism with following values. 0 - 5 = Open (Hybrid Zoom Range) 6 - 10 = Index (Hybrid Zoom Range) 11 - 15 = Rotate Normal (Hybrid Zoom Range) 16 - 20 = Rotate with Mega Stepping (Hybrid Zoom Range) 21 - 25 = Open (Narrow Zoom Range) 26 - 30 = Index (Narrow Zoom Range) 31 - 35 = Rotate Normal (Narrow Zoom Range) 36 - 40 = Rotate with Mega Stepping (Narrow Zoom Range) 41 - 45 = Open (Wide Zoom Range) 46 - 50 = Index (Wide Zoom Range) 51 - 55 = Rotate Normal (Wide Zoom Range) 56 - 60 = Rotate with Mega Stepping (Wide Zoom Range) 61 - 255 = Reserved Values |
| 36 | Prism Index / Rotate - High Byte | 0 - 65535 | 0 - 100% | 32767 | 16 bit control of Prism rotation and index. |
| 37 | Prism Index / Rotate - Low Byte | | | | Rotate Fast to Slow <<< = DMX 0 - 32756 Rotate STOP = DMX 32757 - 32780 Rotate Slow to Fast >>> = DMX 32781 - 65535 |

Table 3: VL4000 BeamWash Enhanced 16-Bit DMX Channel Mapping

| DMX Channel | Parameters | Range (DMX) | Range (%) | Default Value* | Description / Operation |
|-------------|---------------------|-------------|-----------|----------------|--|
| 38 | Programming Control | 0 - 255 | 0 - 100% | 0 | Used as a control channel for different programmable settings. Set discreet value of desired effect, wait >3 seconds, then set value to 0 (Idle). 0 - 2 = Idle 3 - 5 = Reserved Values 6 - 10 = Reserved Values 11 - 15 = Dimmer Snap OFF 16 - 20 = Dimmer Snap ON (Fixture Default) 21 - 255 = Reserved Values |
| 39 | Strobe Speed | 0 - 255 | 0 - 100% | 0 | Controls strobe rate from slowest (DMX 0) to fastest (DMX 255) |
| 40 | Strobe Control | 0 - 255 | 0 - 100% | 0 | Control Channel for strobing functions. 0 - 5 = Open 6 - 10 = Closed 11 - 15 = Normal Strobe 16 - 20 = Random Strobe 21 - 25 = Random Sync 26 - 255 = Reserved Values |
| 41 | Focus Timing | 0 - 255 | 0 - 100% | 255 | Allows for luminaire timing of pan and tilt mechanisms. Profile should default to DMX 255 for smoothest console timing. |
| 42 | Optics Timing | 0 - 255 | 0 - 100% | 255 | Adjustment of fixture timing to control lensing mechanisms. Profile should default to DMX 255 for smoothest console timing. |
| 43 | Color Timing | 0 - 255 | 0 - 100% | 255 | Allows for luminaire timing to control color mechanisms. Profile should default to DMX 255 for smoothest console timing. |
| 44 | Beam Timing | 0 - 255 | 0 - 100% | 255 | Allows for luminaire timing to control beam shaping mechanisms. Profile should default to DMX 255 for smoothest console timing. |
| 45 | Gobo Timing | 0 - 255 | 0 - 100% | 255 | Allows for luminaire timing to control gobo mechanisms. Profile should default to DMX 255 for smoothest console timing. |
| 46 | Luminaire Control | 0 - 255 | 0 - 100% | 0 | To execute a command, the control channel must be set to idle (DMX 0) then changed to a particular value and held for 3 seconds then restored to DMX 0. Upon completion of this routine, the desired command will be executed by the luminaire. Used to strike/douse the lamp, set lamp levels, and other various functions, as well as resetting the luminaire via the console. DMX values are: 0 - 5 = Idle (Default) 6 - 10 = Full Luminaire ReCal (1) (1) This command is also used to Wake fixture up from shutdown 11 - 15 = Lamp ON 16 - 20 = Lamp OFF 21 - 25 = Fixture Shutdown (for more information, see "Fixture Shutdown" on page 44) 26 - 30 = Display - Menu ON 31 - 35 = Display - Menu OFF 36 - 40 = ReCal Position 41 - 45 = ReCal Color 46 - 50 = ReCal Gobo 51 - 55 = ReCal Beam 56 - 60 = ReCal Optics 61 - 65 = ReCal Dimmer/Strobe 66 - 70 = Reset Fixture to Defaults 71 - 75 = Full Luminaire Reboot (2) (2) This command will douse lamp and reset all processors in fixture, then ReCal all parameters. 76 - 80 = Fixture Status On/Off (3) (3) This command will enable the display to show fixture status for 5 min. After this time, displays will return to default configuration. Repeating this command in less than 5 minutes will behave as a toggle. 81 - 85 = Standard Mode - Fixture operates at maximum output (Default) 86 - 90 = Studio Mode - Reduced output with lower fan settings 91 - 255 = Reserved Values |

Notes:

Default Values: *Denotes recommended console default settings.

16-Bit Channel Mapping

Table 4 provides DMX channel mapping of the DMX512 control values when the VL4000 BeamWash Luminaire is in 16-Bit DMX mode (as set by the luminaire's menu system).

Table 4: VL4000 BeamWash 16-Bit DMX Channel Mapping

| DMX Channel | Parameters | Range (DMX) | Range (%) | Default Value* | Description / Operation |
|-------------|-----------------------------|-------------|-----------|----------------|---|
| 1 | Intensity | 0 - 255 | 0 - 100% | 0 | 8-bit control of Fixture Intensity from 0 - 100% |
| 2 | Pan High Byte | 0 - 65535 | 0 - 100% | 32767 | 16-bit linear control of pan from 0° to 520°. |
| 3 | Pan Low Byte | | | | |
| 4 | Tilt High Byte | 0 - 65535 | 0 - 100% | 32767 | 16-bit linear control of tilt from 0° to 270°. |
| 5 | Tilt Low Byte | | | | |
| 6 | Edge High Byte | 0 - 65535 | 0 - 100% | 0 | 16-bit linear control of edge functions. |
| 7 | Edge Low Byte | | | | |
| 8 | Zoom High Byte | 0 - 65535 | 0 - 100% | 0 | 16-bit linear control of fixture zoom range between 0 (4 degrees) to 65535 (60 Degrees). |
| 9 | Zoom Low Byte | | | | |
| 10 | Optic Style | 0 - 255 | 0 - 100% | 0 | Toggles optical ability between Wash, Beam, and Shaft. 0 - 127 = Wash Optics 128 - 191 = Beam Optics 192 - 255 = Shaft Optics |
| 11 | Cyan | 0 - 255 | 0 - 100% | 0 | Controls Cyan color mechanism. |
| 12 | Yellow | 0 - 255 | 0 - 100% | 0 | Controls Yellow color mechanism. |
| 13 | Magenta | 0 - 255 | 0 - 100% | 0 | Controls Magenta color mechanism. |
| 14 | CTO | 0 - 255 | 0 - 100% | 0 | Controls CTO mechanism. |
| 15 | Fixed Color Wheel 1 | 0 - 255 | 0 - 100% | 0 | 8-bit control of Color Wheel 1. See Channel 16 for options. 0 - 23 = OPEN 24 - 69 = RED (Center at DMX 46) 70 - 116 = DARK FUCHSIA (Center at DMX 93) 117 - 162 = ORANGE (Center at DMX 139) 163 - 209 = KELLY GREEN (Center at DMX 186) 210 - 255 = CONGO BLUE (Center at DMX 232) |
| 16 | Fixed Color Wheel 1 Control | 0 - 255 | 0 - 100% | 0 | Used as a control channel for different movement options of Color Wheel 1. 0 - 5 = Linear Movement using shortest (quickest) path. 6 - 10 = Linear Movement using normal (longest) path. 11 - 15 = Wheel Spin Forward (Fast to Slow) 16 - 20 = Wheel Spin STOP 21 - 25 = Wheel Spin Reverse (Slow to Fast) 26 - 56 = Color Shake Quickest Path (Slow to Fast) 57 - 87 = Color Shake Normal Path (Slow to Fast) 88 - 255 = Reserved Values |
| 17 | Fixed Color Wheel 2 | 0 - 255 | 0 - 100% | 0 | 8-bit control of Color Wheel 2. See Channel 18 for options. 0 - 23 = OPEN 24 - 69 = BLUE (Center at DMX 46) 70 - 116 = GREEN (Center at DMX 93) 117 - 162 = MINUS GREEN (Center at DMX 139) 163 - 209 = LAVENDER (Center at DMX 186) 210 - 255 = AMBER (Center at DMX 232) |

Table 4: VL4000 BeamWash 16-Bit DMX Channel Mapping

| DMX Channel | Parameters | Range (DMX) | Range (%) | Default Value* | Description / Operation |
|-------------|---|-------------|-----------|----------------|--|
| 18 | Fixed Color Wheel 2 Control | 0 - 255 | 0 - 100% | 0 | Used as a control channel for different movement options of Color Wheel 2. 0 - 5 = Linear Movement using shortest (quickest) path. 6 - 10 = Linear Movement using normal (longest) path. 11 - 15 = Wheel Spin Forward (Fast to Slow) 16 - 20 = Wheel Spin STOP 21 - 25 = Wheel Spin Reverse (Slow to Fast) 26 - 56 = Color Shake Quickest Path (Slow to Fast) 57 - 87 = Color Shake Normal Path (Slow to Fast) 88 - 255 = <i>Reserved Values</i> |
| 19 | Gobo Wheel 1 | 0 - 255 | 0 - 100% | 0 | 8-bit control of Gobo Wheel 1. See Channel 22 for control options. 0 - 5 = Open - No Gobo 6 - 10 = Gobo 1 (Stacked Ovals) Index 11 - 15 = Gobo 2 (Chopped) Index 16 - 20 = Gobo 3 (Triple Stack) Index 21 - 25 = Gobo 4 (Night Sky) Index 26 - 30 = Gobo 5 (Blades) Index 31 - 35 = Gobo 6 (Psychlone) Index 36 - 40 = Gobo 7 (Circle of Holes 1) Index 41 - 45 = Open - No Gobo 46 - 50 = Gobo 1 (Stacked Ovals) Rotate 51 - 55 = Gobo 2 (Chopped) Rotate 56 - 60 = Gobo 3 (Triple Stack) Rotate 61 - 65 = Gobo 4 (Night Sky) Rotate 66 - 70 = Gobo 5 (Blades) Rotate 71 - 75 = Gobo 6 (Psychlone) Rotate 76 - 80 = Gobo 7 (Circle of Holes 1) Rotate 81 - 85 = Open - No Gobo 86 - 90 = Gobo 1 Gobo 1 (Stacked Ovals) Rotate with Mega Stepping 91 - 95 = Gobo 2 (Chopped) Rotate with Mega Stepping 96 - 100 = Gobo 3 (Triple Stack) Rotate with Mega Stepping 101 - 105 = Gobo 4 (Night Sky) Rotate with Mega Stepping 106 - 110 = Gobo 5 (Blades) Rotate with Mega Stepping 111 - 115 = Gobo 6 (Psychlone) Rotate with Mega Stepping 116 - 120 = Gobo 7 (Circle of Holes 1) Rotate with Mega Stepping 121 - 255 = <i>Reserved Values</i> |
| 20 | Gobo Wheel 1 Index / Rotate - High Byte | 0 - 65535 | 0 - 100% | 32767 | 16 bit control of Gobo Wheel 1 index and rotation. |
| 21 | Gobo Wheel 1 Index / Rotate - Low Byte | | | | Rotate Fast to Slow <<< = DMX 0 - 32756 Rotate STOP = DMX 32757 - 32780 Rotate Slow to Fast >>> = DMX 32781 - 65535 |
| 22 | Gobo Wheel 1 Control | 0 - 255 | 0 - 100% | 0 | Used as a control channel for different movement options for Gobo Wheel 1 (Channel 19). 0 - 5 = Gobo Selection using shortest (quickest) path. 6 - 10 = Gobo Selection using normal (longest) path. 11 - 20 = <i>Reserved Values</i> 21 - 50 = Wheel Spin Forward (Fast to Slow) 51 - 60 = Wheel Spin STOP 61 - 90 = Wheel Spin Reverse (Slow to Fast) 91 - 120 = Gobo Shake Quickest Path (Slow to Fast) 121 - 150 = Gobo Shake Normal Path (Slow to Fast) 151 - 180 = Gobo Twist Quickest Path (Slow to Fast) 181 - 210 = Gobo Twist Normal Path (Slow to Fast) 211 - 255 = <i>Reserved Values</i> |

Table 4: VL4000 BeamWash 16-Bit DMX Channel Mapping

| DMX Channel | Parameters | Range (DMX) | Range (%) | Default Value* | Description / Operation |
|-------------|--|-------------|-----------|----------------|--|
| 23 | Gobo Wheel 2 | 0 - 255 | 0 - 100% | 0 | <p>8-bit control of Gobo Wheel 2.</p> <p>See Channel 26 for control options.</p> <p>0 - 5 = Open - No Gobo 6 - 10 = Gobo 1 (Circle of Eights) Index 11 - 15 = Gobo 2 (Punch Card) Index 16 - 20 = Gobo 3 (Vertical Bars) Index 21 - 25 = Gobo 4 (Lattice) Index 26 - 30 = Gobo 5 (Wavy Triangle) Index 31 - 35 = Gobo 6 (Dot Buffet) Index 36 - 40 = Gobo 7 (Quadcone Red) Index 41 - 45 = Open - No Gobo 46 - 50 = Gobo 1 (Circle of Eights) Rotate 51 - 55 = Gobo 2 (Punch Card) Rotate 56 - 60 = Gobo 3 (Vertical Bars) Rotate 61 - 65 = Gobo 4 (Lattice) Rotate 66 - 70 = Gobo 5 (Wavy Triangle) Rotate 71 - 75 = Gobo 6 (Dot Buffet) Rotate 76 - 80 = Gobo 7 (Quadcone Red) Rotate 81 - 85 = Open - No Gobo 86 - 90 = Gobo 1 (Circle of Eights) Rotate with Mega Stepping 91 - 95 = Gobo 2 (Punch Card) Rotate with Mega Stepping 96 - 100 = Gobo 3 (Vertical Bars) Rotate with Mega Stepping 101 - 105 = Gobo 4 (Lattice) Rotate with Mega Stepping 106 - 110 = Gobo 5 (Wavy Triangle) Rotate with Mega Stepping 111 - 115 = Gobo 6 (Dot Buffet) Rotate with Mega Stepping 116 - 120 = Gobo 7 (Quadcone Red) Rotate with Mega Stepping 121 - 255 = <i>Reserved Values</i></p> |
| 24 | Gobo Wheel 2 Index / Rotate - High Byte | 0 - 65535 | 0 - 100% | 32767 | <p>16 bit control of Gobo Wheel 2 index and rotation.</p> <p>Rotate Fast to Slow <<< = DMX 0 - 32756 Rotate STOP = DMX 32757 - 32780 Rotate Slow to Fast >>> = DMX 32781 - 65535</p> |
| 25 | Gobo Wheel 2 Index / Rotate - Low Byte | | | | |
| 26 | Gobo Wheel 2 Control | 0 - 255 | 0 - 100% | 0 | <p>Used as a control channel for different movement options for Gobo Wheel 2 (Channel 23).</p> <p>0 - 5 = Gobo Selection using shortest (quickest) path. 6 - 10 = Gobo Selection using normal (longest) path. 11 - 20 = <i>Reserved Values</i> 21 - 50 = Wheel Spin Forward (Fast to Slow) 51 - 60 = Wheel Spin STOP 61 - 90 = Wheel Spin Reverse (Slow to Fast) 91 - 120 = Gobo Shake Quickest Path (Slow to Fast) 121 - 150 = Gobo Shake Normal Path (Slow to Fast) 151 - 180 = Gobo Twist Quickest Path (Slow to Fast) 181 - 210 = Gobo Twist Normal Path (Slow to Fast) 211 - 255 = <i>Reserved Values</i></p> |
| 27 | Animation Wheel (<i>Concurrent</i>) | 0 - 255 | 0 - 100% | 0 | Controls Animation Wheel linearly within the beam. |
| 28 | Animation Wheel (<i>Concurrent</i>) Index / Rotate - High Byte | 0 - 65535 | 0 - 100% | 32767 | <p>16 bit control of the Animation Wheel 1 index and rotation.</p> <p>Rotate Fast to Slow <<< = DMX 0 - 32756 Rotate STOP = DMX 32757 - 32780 Rotate Slow to Fast >>> = DMX 32781 - 65535</p> |
| 29 | Animation Wheel (<i>Concurrent</i>) Index / Rotate - Low Byte | | | | |

Table 4: VL4000 BeamWash 16-Bit DMX Channel Mapping

| DMX Channel | Parameters | Range (DMX) | Range (%) | Default Value* | Description / Operation |
|-------------|---|-------------|-----------|----------------|--|
| 30 | Animation Wheel (Concurrent) Control | 0 - 255 | 0 - 100% | 0 | Used as a control channel for Animation Wheel 1. 0 - 5 = Index using shortest (quickest) path. 6 - 10 = Index using normal (longest) path. 11 - 15 = Rotate Normal 16 - 20 = Rotate with Mega Stepping 21 - 25 = Reserved Values 26 - 56 = Image Shake using shortest (quickest) path slow to fast. 57 - 87 = Image Shake using normal (longest) path slow to fast. 88 - 255 = Reserved Values |
| 31 | Iris | 0 - 255 | 0 - 100% | 0 | Controls Iris mechanism from 0 (open) to 255 (full). |
| 32 | Beam Shaping | 0 - 255 | 0 - 100% | 0 | Controls Beam Shaping mechanism with following values. 0 - 5 = Open (Hybrid Zoom Range) 6 - 10 = Index (Hybrid Zoom Range) 11 - 15 = Rotate Normal (Hybrid Zoom Range) 16 - 20 = Rotate with Mega Stepping (Hybrid Zoom Range) 21 - 25 = Open (Narrow Zoom Range) 26 - 30 = Index (Narrow Zoom Range) 31 - 35 = Rotate Normal (Narrow Zoom Range) 36 - 40 = Rotate with Mega Stepping (Narrow Zoom Range) 41 - 45 = Open (Wide Zoom Range) 46 - 50 = Index (Wide Zoom Range) 51 - 55 = Rotate Normal (Wide Zoom Range) 56 - 60 = Rotate with Mega Stepping (Wide Zoom Range) 61 - 255 = Reserved Values |
| 33 | Beam Shaping Index / Rotate - High Byte | 0 - 65535 | 0 - 100% | 32767 | 16 bit control of Beam Shaping rotation and index. |
| 34 | Beam Shaping Index / Rotate - Low Byte | | | | Rotate Fast to Slow <<< = DMX 0 - 32756 Rotate STOP = DMX 32757 - 32780 Rotate Slow to Fast >>> = DMX 32781 - 65535 |
| 35 | Prism | 0 - 255 | 0 - 100% | 0 | Controls Prism mechanism with following values. 0 - 5 = Open (Hybrid Zoom Range) 6 - 10 = Index (Hybrid Zoom Range) 11 - 15 = Rotate Normal (Hybrid Zoom Range) 16 - 20 = Rotate with Mega Stepping (Hybrid Zoom Range) 21 - 25 = Open (Narrow Zoom Range) 26 - 30 = Index (Narrow Zoom Range) 31 - 35 = Rotate Normal (Narrow Zoom Range) 36 - 40 = Rotate with Mega Stepping (Narrow Zoom Range) 41 - 45 = Open (Wide Zoom Range) 46 - 50 = Index (Wide Zoom Range) 51 - 55 = Rotate Normal (Wide Zoom Range) 56 - 60 = Rotate with Mega Stepping (Wide Zoom Range) 61 - 255 = Reserved Values |
| 36 | Prism Index / Rotate - High Byte | 0 - 65535 | 0 - 100% | 32767 | 16 bit control of Prism rotation and index. |
| 37 | Prism Index / Rotate - Low Byte | | | | Rotate Fast to Slow <<< = DMX 0 - 32756 Rotate STOP = DMX 32757 - 32780 Rotate Slow to Fast >>> = DMX 32781 - 65535 |
| 38 | Programming Control | 0 - 255 | 0 - 100% | 0 | Used as a control channel for different programmable settings. Set discreet value of desired effect, wait >3 seconds, then set value to 0 (Idle). 0 - 2 = Idle 3 - 5 = Reserved Values 6 - 10 = Reserved Values 11 - 15 = Dimmer Snap OFF 16 - 20 = Dimmer Snap ON (Fixture Default) 21 - 255 = Reserved Values |
| 39 | Strobe Speed | 0 - 255 | 0 - 100% | 0 | Controls strobe rate from slowest (DMX 0) to fastest (DMX 255) |

Table 4: VL4000 BeamWash 16-Bit DMX Channel Mapping

| DMX Channel | Parameters | Range (DMX) | Range (%) | Default Value* | Description / Operation |
|-------------|-------------------|-------------|-----------|----------------|---|
| 40 | Strobe Control | 0 - 255 | 0 - 100% | 0 | Control Channel for strobing functions. 0 - 5 = Open 6 - 10 = Closed 11 - 15 = Normal Strobe 16 - 20 = Random Strobe 21 - 25 = Random Sync 26 - 255 = Reserved Values |
| 41 | Luminaire Control | 0 - 255 | 0 - 100% | 0 | To execute a command, the control channel must be set to idle (DMX 0) then changed to a particular value and held for 3 seconds then restored to DMX 0. Upon completion of this routine, the desired command will be executed by the luminaire. Used to strike/douse the lamp, set lamp levels, and other various functions, as well as resetting the luminaire via the console. DMX values are: 0 - 5 = Idle (Default) 6 - 10 = Full Luminaire ReCal (1) <i>(1) This command is also used to Wake fixture up from shutdown</i> 11 - 15 = Lamp ON 16 - 20 = Lamp OFF 21 - 25 = Fixture Shutdown (for more information, see "Fixture Shutdown" on page 44) 26 - 30 = Display - Menu ON 31 - 35 = Display - Menu OFF 36 - 40 = ReCal Position 41 - 45 = ReCal Color 46 - 50 = ReCal Gobo 51 - 55 = ReCal Beam 56 - 60 = ReCal Optics 61 - 65 = ReCal Dimmer/Strobe 66 - 70 = Reset Fixture to Defaults 71 - 75 = Full Luminaire Reboot (2) <i>(2) This command will douse lamp and reset all processors in fixture, then ReCal all parameters.</i> 76 - 80 = Fixture Status On/Off (3) <i>(3) This command will enable the display to show fixture status for 5 min. After this time, displays will return to default configuration. Repeating this command in less than 5 minutes will behave as a toggle.</i> 81 - 85 = Standard Mode - Fixture operates at maximum output (Default) 86 - 90 = Studio Mode - Reduced output with lower fan settings 91 - 255 = Reserved Values |

Notes:

Default Values: *Denotes recommended console default settings.

Fixture Shutdown

This command will turn the lamp OFF, disable all motors, and stop the luminaire from functioning until either a Full Luminaire ReCal command or Lamp ON command is sent. When in the shutdown state, the luminaires menu will display **SHUTDOWN**.

Note: The luminaire's cooling fans will continue to run for 5 minutes after the shutdown command is sent. After 5 minutes the luminaire fans will shutdown. A power cycle will also clear the shutdown state.

Luminaire Timing

Luminaire Timing Channel Information

Timing channel control improves the timed moves of certain groups of parameters. Four timing channels are provided, one for Pan and Tilt, one for color parameters, one for beam parameters and one for gobo/index parameters. Timing channels support time values of up to six minutes.

Table 5: Channel Function / Timing Channel Relationship

| Channel Function | Timing Channel | | | | |
|------------------------|----------------|------------|-----------|-----------|-------------|
| | Focus Time | Color Time | Beam Time | Gobo Time | Optics Time |
| Pan (Hi Byte/Lo Byte) | ◆ | | | | |
| Tilt (Hi Byte/Lo Byte) | ◆ | | | | |
| Color | | ◆ | | | |
| Iris | | | ◆ | | |
| Gobos | | | | ◆ | |
| Index | | | | ◆ | |
| Animation Wheel | | | | ◆ | |
| Zoom | | | | | ◆ |
| Edge | | | | | ◆ |
| Beam Shaping | | | | | ◆ |
| Prism | | | | | ◆ |

Types of timing control:

- Timing Control Channel: the luminaire uses its timing channel value to calculate a smooth continuous movement for a given time and transition.
- Console Timing: the console calculates the time duration between the DMX increments to be sent for a given time and transition.

Guidelines:

- Timing channels support time values of up to six minutes.
- To use a timing channel instead of console timing, it is necessary to set the timing channel to the desired value and set cue and/or parameter time to zero. A combination of time controls can produce unexpected results.
- The default value setting in the profile should be 255 (proportional control) to allow smooth movement when using console timing.
- The VL4000 BeamWash Luminaire utilizes an intuitive timing system when the timing channels are set to 255. When quick DMX changes are detected the luminaire will operate as fast as possible and with slower DMX changes the luminaire will operate as smooth as possible.
- The timing channel data should change as a snap. A zero value will give the fastest move, however, without any smoothing this can appear "steppy" in console timed moves.

Note: Some parameters have been excluded from the timing channels. Wheel spin and gobo rotation rate changes are not affected by timing channels.

To use luminaire timing channels, you must:

- Step 1. Create the cue, including color, beam, gobo and position as required.
- Step 2. Decide which fixtures and which parameter groups will use timing channels.
- Step 3. Assign a value to the particular timing channel(s) you wish to use (for timing information see chart on next page).
- Step 4. Set console timing for the luminaire's parameters and timing channels to zero seconds.
- Step 5. Store cue.

Note: Avoid changing timing channel values in a fading cue. This can cause unexpected behavior in the luminaire as the timing channel value is updated over time. Timing channel values and the final destination of the parameters affected by the timing channel should always be sent in a zero count.

Timing channels can be set in either % or 0-255 (DMX) modes, with the following values assigned:

Table 6: Timing Channels Map

| DMX | % Value | = Seconds |
|-----|---------|------------|
| 0 | | Full Speed |
| 1 | | 0.2 |
| 2 | | 0.4 |
| 3 | 1 | 0.6 |
| 4 | | 0.8 |
| 5 | 2 | 1 |
| 6 | | 1.2 |
| 7 | | 1.4 |
| 8 | 3 | 1.6 |
| 9 | | 1.8 |
| 10 | 4 | 2 |
| 11 | | 2.2 |
| 12 | | 2.4 |
| 13 | 5 | 2.6 |
| 14 | | 2.8 |
| 15 | 6 | 3 |
| 16 | | 3.2 |
| 17 | | 3.4 |
| 18 | 7 | 3.6 |
| 19 | | 3.8 |
| 20 | 8 | 4 |
| 21 | | 4.2 |
| 22 | | 4.4 |

Table 6: Timing Channels Map (Continued)

| DMX | % Value | = Seconds |
|-----|---------|-----------|
| 23 | 9 | 4.6 |
| 24 | | 4.8 |
| 25 | 10 | 5 |
| 26 | | 5.2 |
| 27 | | 5.4 |
| 28 | 11 | 5.6 |
| 29 | | 5.8 |
| 30 | | 6 |
| 31 | 12 | 6.2 |
| 32 | | 6.4 |
| 33 | 13 | 6.6 |
| 34 | | 6.8 |
| 35 | | 7.0 |
| 36 | 14 | 7.2 |
| 37 | | 7.4 |
| 38 | 15 | 7.6 |
| 39 | | 7.8 |
| 40 | | 8 |
| 41 | 16 | 8.2 |
| 42 | | 8.4 |
| 43 | 17 | 8.6 |
| 44 | | 8.8 |
| 45 | | 9 |
| 46 | 18 | 9.2 |
| 47 | | 9.4 |
| 48 | 19 | 9.6 |
| 49 | | 9.8 |
| 50 | | 10 |
| 51 | 20 | 10.2 |
| 52 | | 10.4 |
| 53 | | 10.6 |
| 54 | 21 | 11 |
| 55 | | 11 |
| 56 | 22 | 12 |
| 57 | | 12 |
| 58 | | 13 |
| 59 | 23 | 13 |
| 60 | | 14 |
| 61 | 24 | 14 |

Table 6: Timing Channels Map (Continued)

| DMX | % Value | = Seconds |
|-----|---------|-----------|
| 62 | | 14 |
| 63 | | 15 |
| 64 | 25 | 15 |
| 65 | | 16 |
| 66 | 26 | 16 |
| 67 | | 16 |
| 68 | | 17 |
| 69 | 27 | 17 |
| 70 | | 18 |
| 71 | 28 | 18 |
| 72 | | 18 |
| 73 | | 19 |
| 74 | 29 | 19 |
| 75 | | 20 |
| 76 | 30 | 20 |
| 77 | | 20 |
| 78 | | 21 |
| 79 | 31 | 21 |
| 80 | | 21 |
| 81 | | 22 |
| 82 | 32 | 22 |
| 83 | | 23 |
| 84 | 33 | 23 |
| 85 | | 23 |
| 86 | | 24 |
| 87 | 34 | 24 |
| 88 | | 25 |
| 89 | 35 | 25 |
| 90 | | 25 |
| 91 | | 26 |
| 92 | 36 | 26 |
| 93 | | 27 |
| 94 | 37 | 27 |
| 95 | | 27 |
| 96 | | 28 |
| 97 | 38 | 28 |
| 98 | | 29 |
| 99 | 39 | 29 |
| 100 | | 29 |
| 101 | | 30 |
| 102 | 40 | 30 |
| 103 | | 30 |

Table 6: Timing Channels Map (Continued)

| DMX | % Value | = Seconds |
|-----|---------|-----------|
| 104 | | 31 |
| 105 | 41 | 31 |
| 106 | | 32 |
| 107 | 42 | 32 |
| 108 | | 32 |
| 109 | | 33 |
| 110 | 43 | 33 |
| 111 | | 34 |
| 112 | 44 | 34 |
| 113 | | 34 |
| 114 | | 35 |
| 115 | 45 | 35 |
| 116 | | 36 |
| 117 | 46 | 36 |
| 118 | | 36 |
| 119 | | 37 |
| 120 | 47 | 37 |
| 121 | | 38 |
| 122 | 48 | 38 |
| 123 | | 38 |
| 124 | | 39 |
| 125 | 49 | 39 |
| 126 | | 39 |
| 127 | | 40 |
| 128 | 50 | 40 |
| 129 | | 41 |
| 130 | 51 | 41 |
| 131 | | 41 |
| 132 | | 42 |
| 133 | 52 | 42 |
| 134 | | 43 |
| 135 | 53 | 43 |
| 136 | | 43 |
| 137 | | 44 |
| 138 | 54 | 44 |
| 139 | | 45 |
| 140 | 55 | 45 |
| 141 | | 45 |
| 142 | | 46 |
| 143 | 56 | 46 |
| 144 | | 47 |
| 145 | 57 | 47 |

Table 6: Timing Channels Map (Continued)

| DMX | % Value | = Seconds |
|-----|---------|-----------|
| 146 | | 47 |
| 147 | | 48 |
| 148 | 58 | 48 |
| 149 | | 49 |
| 150 | 59 | 49 |
| 151 | | 49 |
| 152 | | 50 |
| 153 | 60 | 50 |
| 154 | | 50 |
| 155 | | 51 |
| 156 | 61 | 51 |
| 157 | | 52 |
| 158 | 62 | 52 |
| 159 | | 52 |
| 160 | | 53 |
| 161 | 63 | 53 |
| 162 | | 54 |
| 163 | 64 | 54 |
| 164 | | 54 |
| 165 | | 55 |
| 166 | 65 | 55 |
| 167 | | 56 |
| 168 | 66 | 56 |
| 169 | | 56 |
| 170 | | 57 |
| 171 | 67 | 57 |
| 172 | | 58 |
| 173 | 68 | 58 |
| 174 | | 58 |
| 175 | | 59 |
| 176 | 69 | 59 |
| 177 | | 59 |
| 178 | | 60 |
| 179 | 70 | 60 |
| 180 | | 65 |
| 181 | 71 | 65 |
| 182 | | 65 |
| 183 | | 70 |
| 184 | 72 | 70 |
| 185 | | 75 |
| 186 | 73 | 75 |
| 187 | | 75 |

Table 6: Timing Channels Map (Continued)

| DMX | % Value | = Seconds |
|-----|---------|-----------|
| 188 | | 80 |
| 189 | 74 | 80 |
| 190 | | 85 |
| 191 | 75 | 85 |
| 192 | | 85 |
| 193 | | 90 |
| 194 | 76 | 90 |
| 195 | | 95 |
| 196 | 77 | 95 |
| 197 | | 95 |
| 198 | | 100 |
| 199 | 78 | 100 |
| 200 | | 110 |
| 201 | 79 | 110 |
| 202 | | 110 |
| 203 | | 120 |
| 204 | 80 | 120 |
| 205 | | 120 |
| 206 | 81 | 130 |
| 207 | | 130 |
| 208 | | 140 |
| 209 | 82 | 140 |
| 210 | | 140 |
| 211 | | 150 |
| 212 | 83 | 150 |
| 213 | | 160 |
| 214 | 84 | 160 |
| 215 | | 160 |
| 216 | | 170 |
| 217 | 85 | 170 |
| 218 | | 180 |
| 219 | 86 | 180 |
| 220 | | 180 |
| 221 | | 190 |
| 222 | 87 | 190 |
| 223 | | 200 |
| 224 | 88 | 200 |
| 225 | | 200 |
| 226 | | 210 |
| 227 | 89 | 210 |
| 228 | | 210 |
| 229 | | 220 |

Table 6: Timing Channels Map (Continued)

| DMX | % Value | = Seconds |
|-----|---------|------------------|
| 230 | 90 | 220 |
| 231 | | 230 |
| 232 | 91 | 230 |
| 233 | | 230 |
| 234 | | 240 |
| 235 | 92 | 240 |
| 236 | | 250 |
| 237 | 93 | 250 |
| 238 | | 250 |
| 239 | | 260 |
| 240 | 94 | 260 |
| 241 | | 270 |
| 242 | 95 | 270 |
| 243 | | 270 |
| 244 | | 280 |
| 245 | 96 | 280 |
| 246 | | 290 |
| 247 | 97 | 290 |
| 248 | | 290 |
| 249 | | 300 |
| 250 | 98 | 300 |
| 251 | | 310 |
| 252 | 99 | 310 |
| 253 | | 310 |
| 254 | | 310 |
| 255 | 100 | Follows Cue Data |

RDM Parameter IDs

VL4000 BeamWash Luminaire RDM Parameter IDs

The following tables outline and describe all the RDM parameters IDs associated with VL4000 BeamWash Luminaires.

- [Table 7, "VL4000 BeamWash Luminaire RDM Product Parameters IDs"](#)
- [Table 8, "VL4000 BeamWash Luminaire RDM UID"](#)
- [Table 9, "VL4000 BeamWash Luminaire RDM Parameters IDs"](#)

Table 7: VL4000 BeamWash Luminaire RDM Product Parameters IDs

| Model ID | Manufacturer | Model Description | Product Category |
|----------|-------------------|-------------------|------------------|
| 0x0030 | Philips Vari-Lite | VL4000 BeamWash | 0x0100 |

Table 8: VL4000 BeamWash Luminaire RDM UID

| UID | | | | | |
|--------------------|--------------------|---------------|--------------------------|-------------------------|---------------|
| MSB of ESTA 56H | LSB of ESTA 4CH | MSB of Serial | Second Byte of Serial | Third Byte of Serial | LSB of Serial |

Table 9: VL4000 BeamWash Luminaire RDM Parameters IDs

| Get Allowed | Set Allowed | RDM Parameter IDs | Value | Comment | Implemented |
|--------------------------------------|-------------|------------------------------------|--------|---|-------------|
| <i>Category - Network Management</i> | | | | | |
| | | DISC_UNIQUE_BRANCH | 0x0001 | | |
| | | DISC_MUTE | 0x0002 | | |
| | | DISC_UN_MUTE | 0x0003 | | |
| | | PROXIED_DEVICES | 0x0010 | | |
| | | PROXIED_DEVICES_COUNT | 0x0011 | | |
| | | COMMS_STATUS | 0x0015 | | |
| <i>Category - Status Collection</i> | | | | | |
| | | QUEUED_MESSAGE | 0x0020 | | ■ |
| ■ | | STATUS_MESSAGES | 0x0030 | | ■ |
| ■ | | STATUS_ID_DESCRIPTION | 0x0031 | | ■ |
| | ■ | CLEAR_STATUS_ID | 0x0032 | | ■ |
| | | SUB_DEVICE_STATUS_REPORT_THRESHOLD | 0x0033 | | |
| <i>Category - RDM Information</i> | | | | | |
| | | SUPPORTED_PARAMETERS | 0x0050 | Support required only if supporting Parameters beyond the minimum required set. | |

Table 9: VL4000 BeamWash Luminaire RDM Parameters IDs

| Get Allowed | Set Allowed | RDM Parameter IDs | Value | Comment | Implemented |
|---|-------------|-----------------------------|--------|--|-------------|
| | | PARAMETER_DESCRIPTION | 0x0051 | Support required for Manufacturer-Specific PIDs exposed in SUPPORTED_PARAMETERS message. | |
| Category - Product Information | | | | | |
| ■ | | DEVICE_INFO | 0x0060 | | ■ |
| | | PRODUCT_DETAIL_ID_LIST | 0x0070 | | |
| ■ | | DEVICE_MODEL_DESCRIPTION | 0x0080 | | ■ |
| ■ | | MANUFACTURER_LABEL | 0x0081 | | ■ |
| ■ | ■ | DEVICE_LABEL | 0x0082 | | ■ |
| | | FACTORY_DEFAULTS | 0x0090 | | |
| | | LANGUAGE_CAPABILITIES | 0x00A0 | | |
| | | LANGUAGE | 0x00B0 | | |
| ■ | | SOFTWARE_VERSION_LABEL | 0x00C0 | | ■ |
| ■ | | BOOT_SOFTWARE_VERSION_ID | 0x00C1 | | ■ |
| ■ | | BOOT_SOFTWARE_VERSION_LABEL | 0x00C2 | | |
| Category - DMX512 Setup | | | | | |
| ■ | ■ | DMX_PERSONALITY | 0x00E0 | | ■ |
| ■ | | DMX_PERSONALITY_DESCRIPTION | 0x00E1 | | ■ |
| ■ | ■ | DMX_START_ADDRESS | 0x00F0 | | ■ |
| ■ | | SLOT_INFO | 0x0120 | | ■ |
| ■ | | SLOT_DESCRIPTION | 0x0121 | | ■ |
| ■ | | DEFAULT_SLOT_VALUE | 0x0122 | | ■ |
| Category - Sensors 0x02xx | | | | | |
| | | SENSOR_DEFINITION | 0x0200 | | |
| | | SENSOR_VALUE | 0x0201 | | |
| | | RECORD_SENSORS | 0x0202 | | |
| Category - Dimmer Settings 0x03xx - FUTURE USE | | | | | |
| Category - Power / Lamp Settings 0x04xx | | | | | |
| ■ | | DEVICE_HOURS | 0x0400 | | ■ |
| ■ | | LAMP_HOURS | 0x0401 | | ■ |
| ■ | | LAMP_STRIKES | 0x0402 | | ■ |
| ■ | ■ | LAMP_STATE | 0x0403 | | ■ |
| ■ | ■ | LAMP_ON_MODE | 0x0404 | | ■ |
| ■ | | DEVICE_POWER_CYCLES | 0x0405 | | ■ |
| Category - Display Settings 0x05xx | | | | | |
| ■ | ■ | DISPLAY_INVERT | 0x0500 | | ■ |
| ■ | ■ | DISPLAY_LEVEL | 0x0501 | | ■ |
| Category - Configuration 0x06xx | | | | | |
| ■ | ■ | PAN_INVERT | 0x0600 | | ■ |
| ■ | ■ | TILT_INVERT | 0x0601 | | ■ |

Table 9: VL4000 BeamWash Luminaire RDM Parameters IDs

| Get Allowed | Set Allowed | RDM Parameter IDs | Value | Comment | Implemented |
|----------------------------------|-------------|-----------------------|--------|---------|-------------|
| ■ | ■ | PAN_TILT_SWAP | 0x0602 | | ■ |
| | | REAL_TIME_CLOCK | 0x0603 | | |
| <i>Category - Control 0x10xx</i> | | | | | |
| | ■ | IDENTIFY_DEVICE | 0x1000 | | ■ |
| | ■ | RESET_DEVICE | 0x1001 | | ■ |
| | | POWER_STATE | 0x1010 | | |
| | | PERFORM_SELFTEST | 0x1020 | | |
| | | SELF_TEST_DESCRIPTION | 0x1021 | | |

Updating Software

PEGASUS Software

Application

With the USB Upload Cable (part number **PEGASUS**, sold separately) and the PEGASUS Software (downloaded from our web site), you can connect any USB 2.0 compatible port on a computer to a chain of up to 32 Philips Entertainment luminaires in order to update the luminaire software.

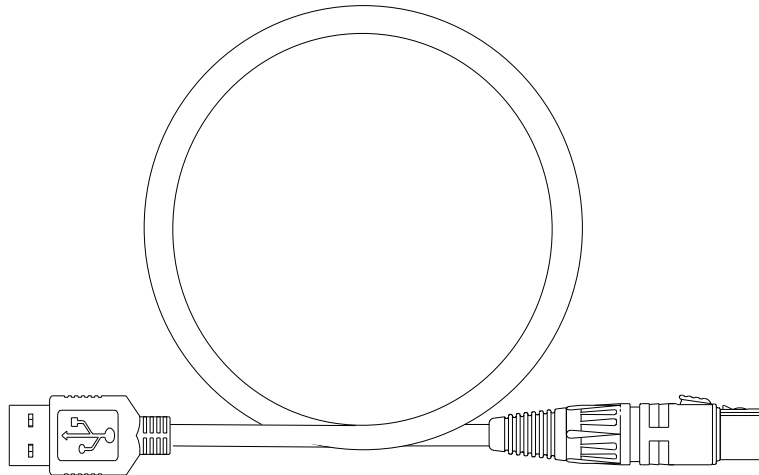

Figure 3-6: USB Upload Cable (sold separately)

Note: PEGASUS Software is compatible with previous versions of the VARI*LITE USB Upload Cable (25.9600.0001).

Computer Requirements

- PC running Windows. Although the programming kit software is not directly compatible with Macintosh computers, it does run with some Windows emulators.
- An available USB 2.0 compatible port on your computer.
- Internet access the Vari-Lite web site (www.vari-lite.com) to download the PEGASUS Software.

Note: Internet access is only required to download the PEGASUS Software and product firmware files. Internet access is not required to use the program.

Installing PEGASUS Software

To install the PEGASUS Software:

- Step 1. Visit the Vari-Lite web site (as described in “[Computer Requirements](#)”) and download PEGASUS Software ZIP File.
- Step 2. Unzip file to a folder on your computer.

- Step 3. Double click on `pegasinstall.msi` icon.
- Step 4. Follow all prompts in program's installation wizard.
- Step 5. Insert USB Upload Cable (*sold separately*) into a USB 2.0 compatible port on your computer.



WARNING: Do not use a USB hub, always connect directly to a USB port on your computer.

- Step 6. When prompted by Windows for upload cable USB driver, use browser window to point to "USB Driver" folder that came with PEGASUS Software and press OK.
- Step 7. After USB cable is ready to use, proceed to next step.

Note: Refer to ““Upload Cable LED Status Messages”” about the three-color LED on the XLR end of the cable.

Troubleshooting

Upload Cable LED Status Messages

Table 10: USB Upload Connector LED Colors

| XLR LED Status | Meaning |
|---|---|
| Continuous Red | Do not use the cable to download software; contact customer service for assistance. |
| Continuous Purple | Driver software is not installed. |
| Continuous Blue with Purple pulse every five seconds. | Cable is ready, but data is not being transmitted. |
| Flashing Blue (twice per second) | Data is being transmitted. |

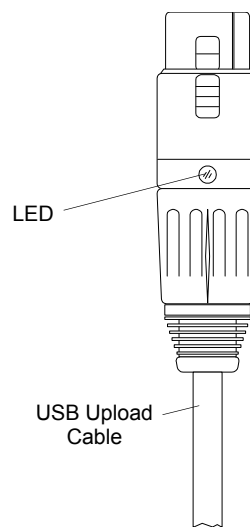

Figure 3-7: USB Upload Cable

Upload Cable Warning (Error) Message

If you see a warning message (as shown in [Figure 3-8](#)) on your computer screen and the USB Upload Cable is properly connected to USB 2.0 compatible port on your computer, it may not be detected by your computer.

- Disconnect USB Upload Cable from computer and reconnect.
- Reinstall USB Upload Cable Driver as described in, “[Installing PEGASUS Software](#)” .

If either of the these do not resolve the error message, you may have a defective Upload Cable. Contact customer service at 1.214.647.7880 or entertainment.service@philips.com for assistance.



Figure 3-8: Upload Cable Error Message

Installing or Updating Luminaire Firmware

Luminaire firmware, for the VL4000 BeamWash Luminaire can be loaded via PEGASUS or via the USB port. This section describes both methods.

USB Upload via USB Port

To upload luminaire software to a luminaire using a USB Flash drive.

- Step 1. On a computer connected to the Internet, download the luminaire software from the Vari-Lite web site. *Save the downloaded .bin file to the root directory on a USB flash drive (not supplied, by others). Do not store the .bin file in any folder on the USB flash drive.*
- Step 2. Insert USB flash drive into luminaire’s USB port.
- Step 3. Press [ESC].
- Step 4. Press [UP] / [DOWN] arrows until **Fixture** appears. Press [OK].
- Step 5. Press [UP] / [DOWN] arrows until **USB** appears. Press [OK].
- Step 6. Press [UP] / [DOWN] arrows until **USB Upload** appears. Press [OK].
- Step 7. The display will show download progress.

Note: To determine software version at luminaire, see “[Verify software version at luminaire:](#)” on [page 61](#).

Using PEGASUS Uploader

When luminaires are data linked together, you can program up to 32 luminaires at the same time; refer to “[Connecting Data and Power](#)” on [page 24](#). To program more than 32 luminaires (or devices), program them in batches of 32 or less.



Important Notes & Warnings:

- *DMX Data must be disconnected before uploading software to luminaires. Do not merge firmware files with DMX signals.*

- You can upload multiple firmware files to a variety of luminaires that are data linked together. Each model of Vari-Lite luminaire recognizes its own software and only downloads the appropriate file.
- Do not use a USB hub, always connect directly to a USB port on your computer.

To install or update luminaire firmware using PEGASUS upload cable:



Note: DMX Data must be disconnected before uploading software to luminaires. Do not merge firmware files with DMX signals.

- Step 1. Visit Vari-Lite web site (www.vari-lite.com) and download product firmware you wish to update.
- Step 2. Unzip firmware file you downloaded to a folder on your computer.
- Step 3. Insert USB Upload Cable (*sold separately*) into a USB 2.0 compatible port on your computer (*do not use a USB hub*).
- Step 4. Double click on PEGASUS Software shortcut on your desktop.
- Step 5. When application opens:
 - a. Select Vari-Lite for luminaire type (as shown in [Figure 3-9](#)).

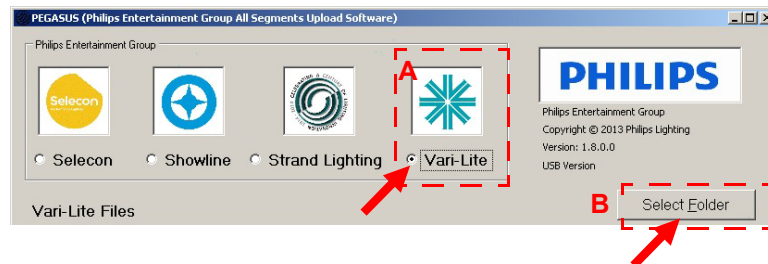

Figure 3-9: PEGASUS Software Selection Screen

- b. As indicated in [Figure 3-9](#), click on Select Folder button to open browser window.
- Step 6. In browser window, navigate to folder where Vari-Lite firmware was extracted.
 - a. Click on any file in folder.
 - b. Click Open button on bottom of screen.

Step 7. Click on bin file for luminaire to be updated (for example, SVL_091813.bin) as highlighted in Figure 3-10.

NOTE: Select High Speed option when uploading to 16 or less luminaires.

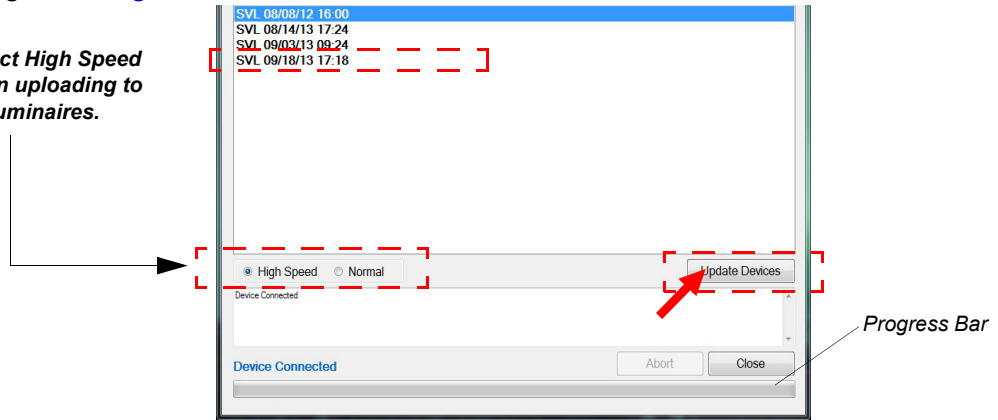

Figure 3-10: bin File Selection

- Step 8. As indicated in Figure 3-10, click on Update Devices to start upload.
- a. During upload, PEGASUS and luminaire screens will display a progress bar showing upload status.
 - b. Once progress bar shows completed on computer screen, wait approximately one minute before moving to next step. *Note, The progress bar on luminaire LCD display may continue for a short time after computer progress bar shows completed.*
 - c. Once the firmware upload is complete, the VARI*LITE luminaire(s) will automatically recalibrate.
- Step 9. Close PEGASUS Software using Close button at bottom of program screen.

Note: You can confirm the software version in the luminaire menu.

Transferring Software From Luminaire to Luminaire

It is possible to transfer specific software versions between luminaires. As in the case of installing new software versions, multiple luminaires can be programmed at the same time if they are data linked together (refer to “[Connecting Data and Power](#)” on page 24), however a maximum of 32 luminaires can be updated at once.

Hardware Requirements

Data cables used in this process must have two twisted pairs and a shield. It is also recommended that cables meet all other USITT DMX specification requirements. Refer to “[Data Cables](#)” on page 15.

A DMX termination connector is used in this process. Refer to [page 16](#) for more information regarding the construction of this connector.

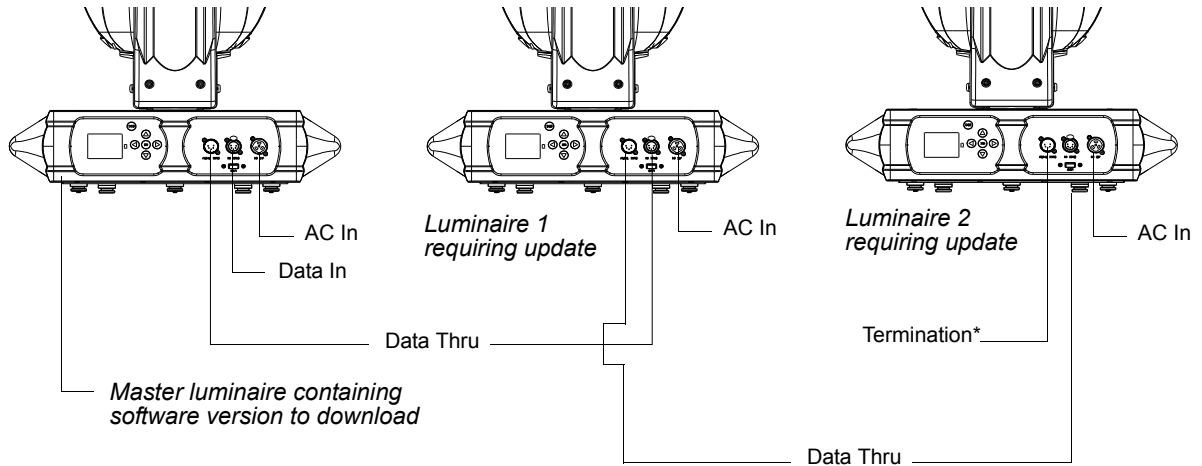

*DMX terminator required for last fixture on DMX line.

Figure 3-11: Software Transfer Setup

Transfer Procedure

This procedure is used to transfer software versions between luminaires.

- Step 1. At last luminaire, install DMX termination connector into DATA THRU XLR connector.
- Step 2. At master luminaire (first in chain) Menu Display, press [ESC].
- Step 3. Press [Up] / [Down] arrows until **Fixture** appears. Press [OK].
- Step 4. Press [Up] / [Down] arrows until **Crossload Software** appears. Press [OK].
- Step 5. OK? will be displayed. Press [OK] to accept.
- Step 6. The status bar will show download progress.

Verify software version at luminaire:

- Step 1. At Menu Display, press [ESC].
- Step 2. Press [Up] / [Down] arrows until **Fixture** appears. Press [OK].
- Step 3. Press [Up] / [Down] arrows until **Version** appears. Press [OK].

The first half of the version will be displayed as a date (MM/DD/YY). For example, 03/18/14 (March 18, 2014).

Press [Enter] to display second half of version. This will be displayed as a time (HH:MM). (For example, 16.36 = 4:36 pm).

Notes

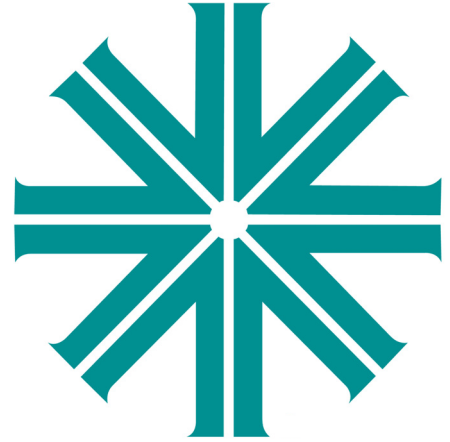

CHAPTER 4.

Menu System

This chapter contains instructions for operating the luminaire using the Menu Display feature.

- **Menu Operation**
- **Self Tests**
- **Service Menu Items**

Menu Operation

LCD Display and Menu System

The VL4000 BeamWash Luminaire's LCD Display and Menu System provides local control for accessing the following fixture's settings:

- Address – to set the DMX address
- Configure – various parameter settings, set luminaire ID
- DMX – change the map, view incoming DMX, invert pan/tilt
- Fixture – fixture status, recalibrate, reboot, software version, view fixtures hours, service, etc.
- Manual – manual control of parameters
- Test – test functions of parameters

The menu system is controlled at the Menu Display available at the enclosure input panel. If there are multiple luminaires in a system, any settings or changes would need to be made at each LCD Menu as desired.

Menu Controls

The menu system is controlled by an OK (Enter), ESC (Escape), and four Arrow (<△▽▷) buttons. These buttons function are shown in [Figure 4-1](#).

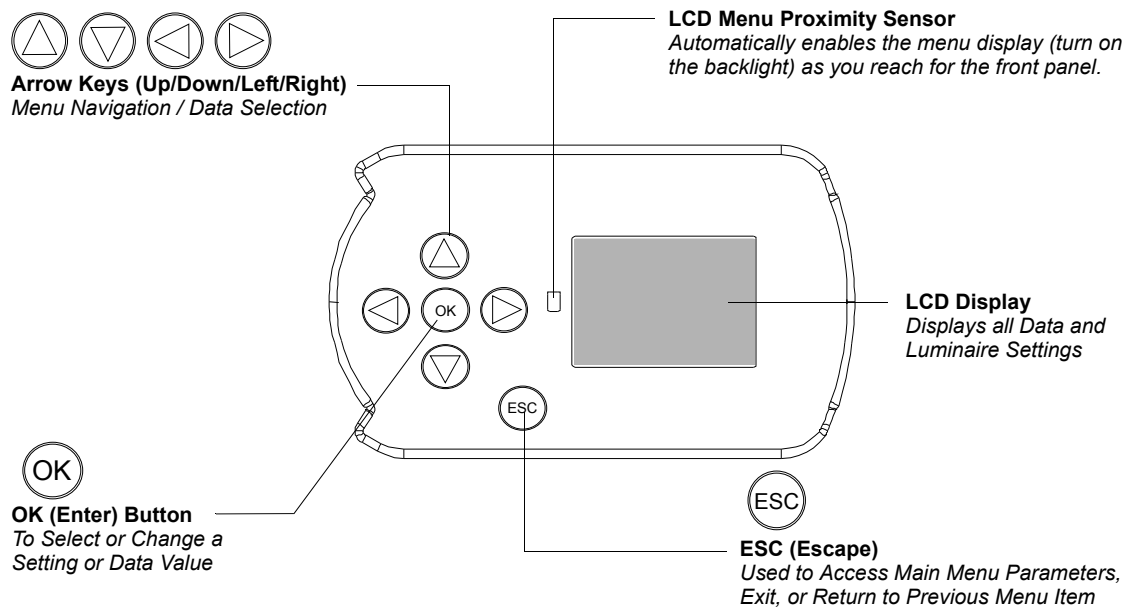

Figure 4-1: Menu Control

LCD Display and Menu System Operation

The LCD Display Menu system consists of several categories. Use the Menu Buttons to access and make changes to the menu items. When the desired menu item is reached, press the desired Menu Button to display the menu options and to navigate and configure the menu options as required.

To navigate and access menu settings/selections:

- Step 1. Make sure unit is powered and turned on.
- Step 2. Press [ESC] to access menu categories.
- Step 3. Use four Arrow (◀△▽▶) buttons to navigate through the various options and settings.
- Step 4. Once menu item is reached, press [OK] to access the menu item parameters.
- Step 5. Make changes to parameters as desired.
- Step 6. Press OK [Enter] button to accept changes.

DMX Address

To set, edit, and save a DMX address:

- Step 1. Press [ESC].
- Step 2. Press [Up] / [Down] arrows until **Address** appears. Press [OK].
- Step 3. Use [Left] and [Right] arrow buttons to scroll through all digits.
- Step 4. Once at desired digit, use [Up] and [Down] arrows to change highlighted digit.
- Step 5. Once digit is set, use [Left] and [Right] arrow buttons to set other digits in DMX address.
- Step 6. Once all digits are set in DMX address, press [OK] to set.
- Step 7. DMX address will display and is saved.

Operational Modes - Standard and Studio

The VL4000 BeamWash Luminaire offers users the choice of two operational modes that are selectable through the luminaire's menu system:

- **Standard Mode** (*default*) - luminaire's cooling fans are set to maximum cooling to allow the luminaire to output up to 42,000 lumens. In Standard Mode, the fixture can operate in environments up to 104° F / 40° C.
- **Studio Mode** - luminaire's cooling fans are slowed to afford quieter operation where noise could be a concern. The lumen output of the fixture is reduced to 35,000 lumens to minimize the heat produced by the luminaire's lamp. In Studio Mode, the fixture can operate in environments up to 122° F / 50° C.

Note: The operational mode can be changed at any time during use via the control channel. This allows the unit to be put in Studio mode only for particular instances or scenes within during its use.

Other LCD Display Features

LCD Menu Battery Operation

The LCD menu system utilizes a battery powered system for operation when the luminaire is not connected to power. The primary purpose of this mode is to allow basic setup and configuration of the luminaire.

To enable the battery operation of the menu system:

- Step 1. Press and hold [ESC] and [OK] for two seconds.
- Step 2. Once enabled, the menu will function as normal.

Note: Any commands that require full power (calibrate, lamp strike, etc.) will be ignored while the menu system is in battery operation mode.

- Step 3. To exit battery mode, press and hold [ESC] and [OK] for two seconds. *Note, luminaire will automatically exit this mode after one minute of inactivity.*

Status Bar

The Status Bar (as illustrated in [Figure 4-2](#)) is present at all times and displays luminaire operational information of the luminaire. The Status Bar contains the following information:

- LAMP – indicates current lamp state - ON or OFF.
- MODE – indicates STA for Standard Mode or STU for Studio Mode.
- ERRORS – Displays a number indicating the total amount of current errors. When errors are present, messages will appear in Red text. When no errors are present, NO will display.
- MAP – Displays the current DMX map setting - 16E for enhanced 16-bit mode or 16 for 16-bit mode.
- ADDR – Displays the current DMX address for the fixture. NOTE, when the fixture does not detect a DMX input signal, the DMX address text will display in Red text.



Figure 4-2: LCD Display Status Bar

LCD Menu Proximity Sensor

The LCD menu system uses a proximity sensor to automatically enable the menu display (turn on the backlight) as you reach for the front panel. If the display is off, it will turn on when your hand is within a few inches of the display. *Note, when the luminaire is not connected to power and the LCD menu is operating on battery, this proximity sensor is disabled.*

Menu Tree

Figure 4-3 and Figure 4-4 on page 68 are graphical representations of the menu system.



Figure 4-3: Menu Tree Part 1

Continued from previous page:



Figure 4-4: Menu Tree Part 2

Menu System Functions

Table 4-1: Menu System Chart

| 1st Level | 2nd Level | 3rd Level | 4th Level | 5thLevel |
|--|--|---|--|----------|
| Address <i>DMX Address</i> | XXX <i>DMX Address value 1 to 512</i> | | | |
| Configure <i>System Configuration</i> | Lamp <i>Lamp Options</i> | Power | ON (default) | |
| | | | OFF | |
| | | Power Up <i>Lamp Power-up State</i> | Lamp OFF (default) <i>Lamp Off</i> | |
| | | | Lamp ON <i>Lamp On</i> | |
| | | | Cal ON | |
| | | Lamp Level <i>Setting the fixture to either Standard (STA) or Studio (STU) mode</i> | Standard* | |
| | | | Studio | |
| | Lamp Hours <i>Lamp Hours Used</i> | XXXX <i>Cumulative # of Operation Hours</i> | | |
| | Lamp Strikes <i>Number of Lamp Strikes Performed</i> | XXXX <i>Cumulative # of Lamp Strikes</i> | | |
| | Reset Lamp Hours <i>Resets Lamp Hour Counter</i> | Are you sure? <i>Resets Lamp Hour Counter to 0000</i> | <i>Confirmation that reset has been executed</i> | |
| | Pan/Tilt <i>Pan and Tilt Options</i> | Movement <i>Position Recovery</i> | Enable | |
| | | | Disable | |
| | | Speed <i>Pan / Tilt movement speed</i> | Auto | |
| | | | Normal | |
| | Head Motors | Movement | Enable | |
| | | | Disable | |
| | Display <i>Display / Menu Illumination</i> | Orientation | Auto <i>Flips to enclosure position</i> | |
| | | | Up | |
| | | | Down | |
| | | On Time | 30 Seconds <i>OFF in 30 seconds</i> | |
| | | | 5 Minutes <i>OFF in 5 minutes</i> | |
| 10 Minutes <i>OFF in 10 minutes</i> | | | | |
| ON <i>ON indefinitely</i> | | | | |
| Reset Defaults <i>Reset luminaire to default settings?</i> | Are you sure? | <i>Confirmation that reset has been executed</i> | | |
| Change Luminaire ID | ##### <i>Sets Luminaire ID Number</i> | | | |

Table 4-1: Menu System Chart (Continued)

| 1st Level | 2nd Level | 3rd Level | 4th Level | 5thLevel |
|---------------------------------------|---|--|---------------|----------|
| DMX DMX Data and Pan/Tilt Mode | DATA Note: Channel and Dimmer information displayed simultaneously | Ch 1 - Intensity XXX (Value) | | |
| | | Ch 2 - Pan High Byte XXX (Value) | | |
| | | Ch 3 - Pan Low Byte XXX (Value) | | |
| | | Ch 4 - Tilt High Byte XXX (Value) | | |
| | | Ch 5 - Tilt Low Byte XXX (Value) | | |
| | | Ch 6 - Edge High Byte XXX (Value) | | |
| | | Ch 7 - Edge Low Byte XXX (Value) | | |
| | | Ch 8 - Zoom High Byte XXX (Value) | | |
| | | Ch 9 - Zoom Low Byte XXX (Value) | | |
| | | Ch 10 - Optic Style XXX (Value) | | |
| | | Ch 11 - Cyan XXX (Value) | | |
| | | Ch 12 - Yellow XXX (Value) | | |
| | | Ch 13 - Magenta XXX (Value) | | |
| | | Ch 14 - CTO XXX (Value) | | |
| | | Ch 15 - Col Whl 1 XXX (Value) | | |
| | | Ch 16 - Col Whl 1 Ctrl XXX (Value) | | |
| | | Ch 17 - Col Whl 2 XXX (Value) | | |
| | | Ch 18 - Col Whl 2 Ctrl XXX (Value) | | |
| | | Ch 19 - Gobo Whl 1 XXX (Value) | | |
| | | Ch 20 - Gobo 1 Indx High XXX (Value) | | |
| | | Ch 21 - Gobo 1 Indx Low XXX (Value) | | |
| | | Ch 22 - Gobo 1 Ctrl XXX (Value) | | |
| | | Ch 23 - Gobo Whl 2 XXX (Value) | | |
| | | Ch 24 - Gobo 2 Indx High XXX (Value) | | |
| | | Ch 25 - Gobo 2 Indx Low XXX (Value) | | |
| | | Ch 26 - Gobo 2 Ctrl XXX (Value) | | |
| | | Ch 27 - Animation Whl XXX (Value) | | |
| | | Ch 28 - Animation Indx High XXX (Value) | | |
| | | Ch 29 - Animation Indx Low XXX (Value) | | |
| | | Ch 30 - Animation Ctrl XXX (Value) | | |
| | | Ch 31 - Iris XXX (Value) | | |
| | | Ch 32 - Beam Shaping XXX (Value) | | |
| | | Ch 33 - Beam Shaping High XXX (Value) | | |
| | | Ch 34 - Beam Shaping Low XXX (Value) | | |
| | | Ch 35 - Prism XXX (Value) | | |
| | | Ch 36 - Prism Index High XXX (Value) | | |
| | | Ch 37 - Prism Index Low XXX (Value) | | |
| | | Ch 38 - Programming Control XXX (Value) | | |
| | | Ch 39 - Strobe Speed XXX (Value) | | |
| | | Ch 40 - Strobe Control XXX (Value) | | |
| | | Ch 41 - Focus Timing XXX (Value) | | |
| | | Ch 42 - Optics Timing XXX (Value) | | |
| | | Ch 43 - Color Timing XXX (Value) | | |
| | | Ch 44 - Beam Timing XXX (Value) | | |
| | | Ch 45 - Gobo Timing XXX (Value) | | |
| | | Ch 46 - Luminaire Ctrl XXX (Value) | | |
| | Pan/Tilt Pan/Tilt Options | Swap Pan / Tilt Swap Pan & Tilt operation | OFF (default) | |
| ON | | | | |
| Invert Pan Inverts Pan operation | | OFF (default) | | |
| | | ON | | |
| Invert Tilt Inverts Tilt operation | OFF (default) | | | |
| | ON | | | |
| DMX Mode Sets DMX Mapping Mode | | 16-bit Enh 16-Bit Enhanced DMX Mode (default) | | |
| | | 16-bit 16-bit DMX Mode | | |

Table 4-1: Menu System Chart (Continued)

| 1st Level | 2nd Level | 3rd Level | 4th Level | 5thLevel | | |
|--|--|---|--|---------------------------|-------------------------------|--|
| Fixture <i>Displays fixture information, condition or downloads new software</i> | Status <i>Status/Error Display</i> | Fixture OK <i>. . . Or displays a list of errors encountered during calibration process or operation.</i> | | | | |
| | ReCalibrate Fixture <i>Recalibrate (re-homes) all mechanical parameters of the fixture</i> | Are you sure? | <i>Confirmation that recalibration has been executed</i> | | | |
| | ReBoot Fixture <i>Reboots entire fixture including processor</i> | Are you sure? | | | | |
| | Luminaire ID <i>Displays luminaire's ID number</i> | ##### | | | | |
| | Software Version <i>Current software installed in fixture</i> | XX/XX/XX <i>Software Version Date</i> | XX:XX <i>Software Version Time</i> | | | |
| | Fixture Hours <i>Fixture Hours On (powered)</i> | XXXXXX <i>Hours</i> | | | | |
| | Crossload Software <i>Download (send) fixture's software to other connected fixtures.</i> | Send | Sending Version XX/XX/XX XX:XX <i>Sending Software Version Date / Time</i> | Crossload Complete | | |
| | Service <i>For use by authorized service technicians only.</i> | | Service Settings | Set Tilt Cal | | |
| | | | | Gobo Menu | Gobo 1 Offset | |
| | | | | | Gobo 2 Offset | |
| | | | | | Reset Gobo Offsets | |
| | | | | | Recalibrate Gobo | |
| | | | | BeamShape Menu | BeamShape Offset | |
| | | | | | Reset BeamShape Offset | |
| | | | | | Recalibrate BeamShape | |
| Prism Menu | | | | Prism Offset | | |
| | | | | Reset Prism Offset | | |
| | Recalibrate Prism | | | | | |
| Diagnostics | Ballast Info | | | | | |
| | Fan Check | | | | | |
| | Board Check | | | | | |
| | Sensor Check | | | | | |
| | Debug | | | | | |
| USB | Update OS | List of Files <i>OR</i> No Card Inserted | | | | |
| | | Download | | | | |
| | Log File | Reset | | | | |

For Service Settings and USB menu descriptions, refer to the following:

- [“Set Tilt Cal” on page 75](#)
- [“Gobo Offset” on page 76](#)
- [“USB Logging” on page 76 \(for Log File\)](#)
- [“Installing or Updating Luminaire Firmware” on page 58 \(for Update OS\)](#)

Table 4-1: Menu System Chart (Continued)

| 1st Level | 2nd Level | 3rd Level | 4th Level | 5thLevel |
|---|--|--|-----------------------------------|----------|
| Manual <i>Manual</i> <i>Commands</i> <i>Note: Manual is Disabled if DMX512 signal is present.</i> | Intensity Pan Tilt Edge Zoom Optic Style Cyan Yellow Magenta CTO Col Whl 1 Col Whl 1 Ctrl Col Whl 2 Col Whl 2 Ctrl Gobo Whl 1 Gobo 1 Rotate / Index Gobo 1 Ctrl Gobo Whl 2 Gobo 2 Rotate/Index Gobo 2 Ctrl Animation Whl Animation Rotate / Index Animation Ctrl Iris Beam Shaping Beam Shaping Rotate / Index Prism Prism Rotate / Index Programming Control Strobe Speed Strobe Control | <i>Value 0 - 255</i> <i>Value 0 - 65535</i> <i>Value 0 - 65535</i> <i>Value 0 - 65535</i> <i>Value 0 - 65535</i> <i>Value 0 - 255</i> <i>Value 0 - 255</i> <i>Value 0 - 255</i> <i>Value 0 - 255</i> <i>Value 0 - 255</i> <i>Value 0 - 255</i> <i>Value 0 - 255</i> <i>Value 0 - 255</i> <i>Value 0 - 255</i> <i>Value 0 - 65535</i> <i>Value 0 - 255</i> <i>Value 0 - 255</i> <i>Value 0 - 65535</i> <i>Value 0 - 255</i> <i>Value 0 - 255</i> <i>Value 0 - 65535</i> <i>Value 0 - 255</i> <i>Value 0 - 255</i> <i>Value 0 - 255</i> <i>Value 0 - 65535</i> <i>Value 0 - 255</i> <i>Value 0 - 255</i> <i>Value 0 - 65535</i> <i>Value 0 - 255</i> <i>Value 0 - 255</i> | | |
| Test* <i>System Test</i> <i>Note: Test is Disabled if DMX512 signal is present.</i> | ALL Test Pan/Tilt Pan Tilt Dimmer Strobe Color Mixing Cyan Yellow Magenta CTO Color Wheel 1 Color Wheel 2 Gobo 1 Gobo 2 Animation Iris Edge Zoom Prism Lamp Encoder Pan Encoder Tilt | <i>Running 'ALL TEST'</i> <i>Running 'PAN/TILT TEST'</i> <i>Running 'PAN TEST'</i> <i>Running 'TILT TEST'</i> <i>Running 'DIMMER TEST'</i> <i>Running 'STROBE TEST'</i> <i>Running 'COLOR MIXING TEST'</i> <i>Running 'CYAN TEST'</i> <i>Running 'YELLOW TEST'</i> <i>Running 'MAGENTA TEST'</i> <i>Running 'CTO TEST'</i> <i>Running 'COL WHL 1 TEST'</i> <i>Running 'COL WHL 2 TEST'</i> <i>Running 'GOBO 1 TEST'</i> <i>Running 'GOBO 2 TEST'</i> <i>Running 'ANIMATION TEST'</i> <i>Running 'IRIS TEST'</i> <i>Running 'EDGE TEST'</i> <i>Running 'ZOOM TEST'</i> <i>Running 'PRISM TEST'</i> <i>Lamp Adjustment Mode Enabled</i> <i>XXXXXXX - Displays Pan Encoder</i> <i>XXXXXXX - Displays Tilt Encoder</i> | <i>Press [Menu] to stop tests</i> | |

Self Tests

Running Parameter Tests

The luminaire is capable of running self tests by using the TEST menu functions. For complete details and values for each test refer to “Diagnostic Tests” on page 74.

When running tests on multiple luminaires, a DMX termination connector is required at the last luminaire in the link. (Refer to page 16 for more information regarding the construction of this connector.).

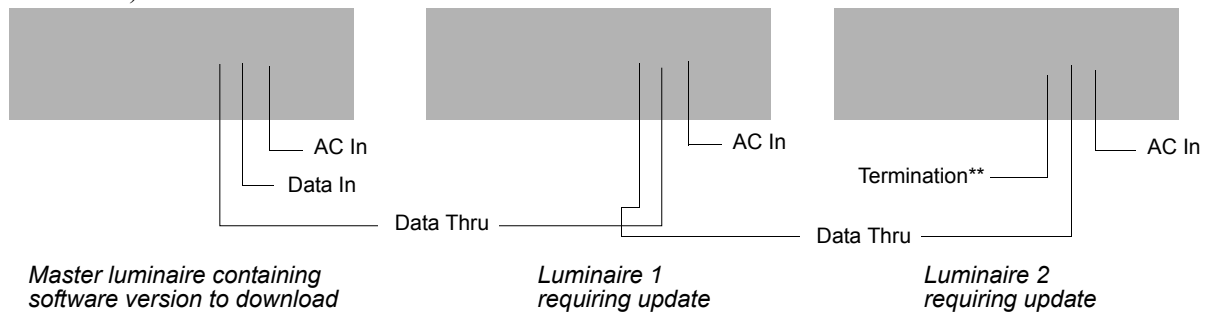

**DMX terminator required for last fixture on DMX line.

Figure 4-5: Test Setup

To run tests:

- Step 1. Press [ESC].
- Step 2. Press [Up] / [Down] arrows until **Test** appears. Press [OK].
- Step 3. Use [Up] / [Down] arrows to select a parameter to test. Refer to “Menu System Functions” on page 69 for a complete list of test parameters which can be chosen.
- Step 4. Press [OK] to run test.
- Step 5. Press [ESC] to stop test at any time.

Note: Connected luminaires may not respond on the first action (may delay) of the master luminaire.

Movement Disable

The **Movement** option allows pan and tilt to be disabled so that the luminaire can be placed in any position for testing without movement occurring. In order to regain full control of the luminaire, **Movement** will need to be enabled after testing.

Note: When using the **Movement** option, pan and tilt will be disabled for all the luminaires that are linked.

To set movement option:

- Step 1. Press [ESC].
- Step 2. Press [Up] / [Down] arrows until Config appears. Press [OK].
- Step 3. Press [Up] / [Down] arrows until Pan/Tilt appears. Press [OK].
- Step 4. Movement will be displayed. Press [OK].
- Step 5. Use [Up] / [Down] arrows to select Enable or Disable. Press OK] to select.

Diagnostic Tests

The following diagnostic tests are available in the test menu. Press [Menu] at anytime to stop test.

Test Descriptions

| <u>Test Name</u> | <u>Display</u> |
|-----------------------|---------------------------------------|
| ALL Test | Running 'ALL TEST' |
| Pan/Tilt | Running 'PAN/TILT TEST' |
| Pan | Running 'PAN TEST' |
| Tilt | Running 'TILT TEST' |
| Dimmer..... | Running 'DIMMER TEST' |
| Strobe..... | Running 'STROBE TEST' |
| Color Mixing | Running 'COLOR MIXING TEST' |
| Cyan..... | Running 'CYAN TEST' |
| Yellow | Running 'YELLOW TEST' |
| Magenta | Running 'MAGENTA TEST' |
| CTO..... | Running 'CTO TEST' |
| Color Wheel 1 | Running 'COL WHL 1 TEST' |
| Color Wheel 2 | Running 'COL WHL 2 TEST' |
| Gobo 1 | Running 'GOBO 1 TEST' |
| Gobo 2 | Running 'GOBO 2 TEST' |
| Animation | Running 'ANIMATION TEST' |
| Iris | Running 'IRIS TEST' |
| Framing Shutters..... | Running 'FRAMING SHUTTERS TEST' |
| Edge..... | Running 'EDGE TEST' |
| Zoom | Running 'ZOOM TEST' |
| Prism | Running 'PRISM TEST' |
| Lamp | Lamp Adjustment Mode Enabled |
| Encoder Pan | XXXXXXX - Displays Pan Encoder Value |
| Encoder Tilt | XXXXXXX - Displays Tilt Encoder Value |

Service Menu Items

Refer to “Menu Tree” on page 67 for more information.

CAUTION: Certain features described below are for Authorized Service Centers and Certified Vari-Lite Technicians use only.

Set Tilt Cal

Set Tilt Calibration (Set Tilt Cal) menu under the Fixture -> Service menu. This feature improves the centering calibration of the tilt parameter. For the best performance users are advised to calibrate the tilt using the luminaire's LCD menu as described below.

To Set Tilt Cal:

- Step 1. Press [UP] / [DOWN] arrows until **Service** appears. Press [OK].
- Step 2. Press [UP] / [DOWN] arrows until **Set Tilt Cal** appears. Press [OK].
- Step 3. The display will read **Set Tilt Encoder Center Tilt Position Press OK** and the tilt motors will disengage.
- Step 4. Manually move by hand the tilt of the luminaire's head until it is in alignment with the yoke arm as shown in [Figure 5](#).

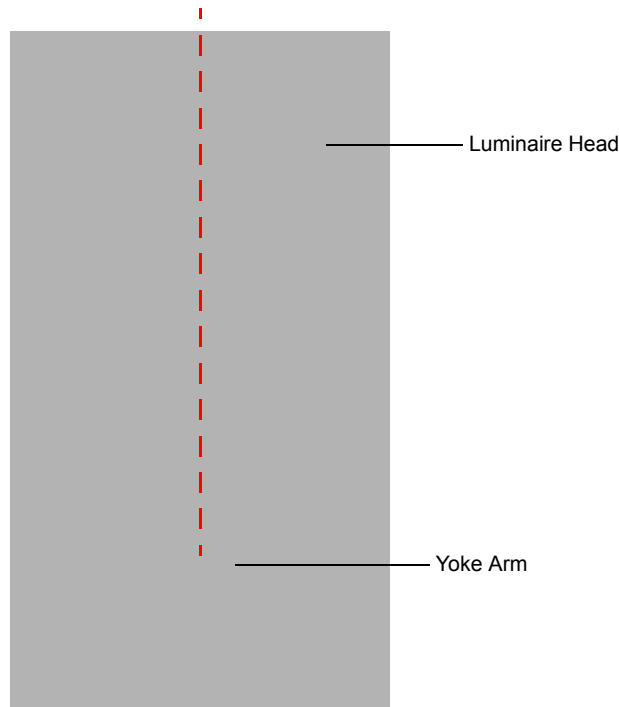

Figure 5: VL4000 BeamWash Luminaire

- Step 5. Press [OK] to accept the calibration or [ESC] to cancel the calibration.

Gobo Offset

Gobo Offset (for each Gobo Wheel) menu under the Fixture -> Service menu - The luminaire software provides the ability to adjust the offset of each gobo wheel was implemented. Gobo Offset should only be adjusted if a wheel is not properly centering gobos in the aperture.

CAUTION: This feature should only be performed by Authorized Service Centers and Certified Vari-Lite Technicians.

To Set Gobo Offset for gobo wheel 1 and/or gobo wheel 2:

- Step 1. Using a DMX console or manual control, select a gobo on the desired wheel and adjust the edge parameter accordingly.
 - Step 2. Press [UP] / [DOWN] arrows until **Service** appears. Press [OK].
 - Step 3. Press [UP] / [DOWN] arrows until **Gobo 1 Offset** or **Gobo 2 Offset** appears. Press [OK].
 - Step 4. The display will read **0** (zero). Use the [UP] / [DOWN] arrows to move selected gobo wheel within the aperture as desired.
 - Step 5. Press [OK] to accept and store the gobo offset setting or [ESC] to cancel the gobo offset setting.
 - Step 6. After pressing [OK], adjusted gobo wheel will recalibrate to its new offset value.
-

USB Logging

The VL4000 BeamWash Luminaire stores error messages in a log file within the luminaire. This information along with specific luminaire settings can be saved as a .csv (*comma-separated values*) file to a USB flash drive connected to the USB port.

To save the current log file to a USB Flash Drive:

- Step 1. Insert a USB flash drive (*not supplied, by others*) into luminaire's USB port.
- Step 2. Press [ESC].
- Step 3. Press [UP] / [DOWN] arrows until **Fixture** appears. Press [OK].
- Step 4. Press [UP] / [DOWN] arrows until **USB** appears. Press [OK].
- Step 5. Press [UP] / [DOWN] arrows until **USB Log** appears. Press [OK].
- Step 6. Press [UP] / [DOWN] arrows until **DOWNLOAD** appears. Press [OK].
- Step 7. Once the download is complete, the display will read "**Reset Current Lum error log file?**" Press [OK] to reset or [ESC] to exit.
- Step 8. Press [OK] to clear the current log file in the luminaire or [ESC] to keep it.

The .csv log file on the USB Flash Drive can be read via any computer system. The file name will be as follows: 4KSxxxx.csv (the xxxxx will be the unique luminaire ID of the fixture). Each log file contains labels and values as shown in Table 5 on page 77.

Table 5: .csv Log File Information

| Parameter | Example Information | Meaning |
|------------------|---------------------|--|
| Model | VL4000 BeamWash | The fixture model |
| Fixture Hours | 142 | The total of number of hours the fixture has been operating |
| DMX Address | 1 | Current DMX address of the fixture as set by the user |
| RDM UID | 56:4c:2f:0:7:2a | Refer to "RDM Parameter IDs" on page 53 for information |
| Luminaire ID | 1834 | Current luminaire identification number |
| Software Version | 1/6/2015 | Current software version loaded in the fixture |
| DMX Map | 16-bit Enh | Current DMX mode setting (16 bit enhanced or 16 bit) |
| Swap Pan/Tilt | No | Current pan and tilt setting |
| Invert Pan | No | Current pan operation setting |
| Invert Tilt | No | Current tilt operation setting |
| Lamp Power Up | Lamp Off | Current Lamp Power Up option setting (Lamp Off, Lamp ON, or Cal On) |
| Lamp Level | Standard | Current operating mode of the fixture (Standard or Studio) |
| Lamp Strikes | 518 | Total number of lamp strikes initiated by the fixture |
| Lamp Hours | 140 | Total number of lamp hours since the last lamp hour reset |
| Fixture Hour | Error Type(s) | Lists any errors and their associated fixtures hour (in example shown, a pan error occurred at fixture hour 138) |
| 138 | Pan no sensor | |

Notes

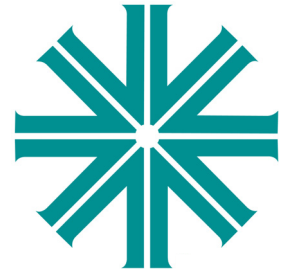

APPENDIX A.

Maintenance

This appendix provides instructions for performing routine maintenance which may be necessary during the life of the luminaire.

- **Equipment Handling**
- **Troubleshooting**
- **Routine Maintenance**



WARNING: All maintenance procedures are to be performed with power completely removed from the luminaire. Also, allow at least of five minutes cooling time before opening covers. Never remove covers or lamp cover assembly while lamp is in operation.

Equipment Handling

Below are some basic tips and information on handling luminaires and their associated components.

Locations/Use



VARI*LITE luminaires are designed for dry locations only. Exposure to rain or moisture (including, but not limited to, fog machines, misters, etc.) may damage luminaire.

Lamps

Servicing

- When handling a lamp, hold it by the ceramic base while wearing cotton gloves or finger cots. Do not touch the glass envelope (bulb). If you touch the glass with bare fingers, immediately wipe off any fingerprints with isopropyl alcohol.
- Use care when removing and replacing covers of luminaire and cleaning reflectors. Any jarring can undo the optical alignment of the lamp.
- Hot Lamp. Luminaire must remain powered on for 5 minutes after dousing lamp. Do not open for 5 minutes after switching off. Lampe chaude. Le luminaire doit rester en marche pendant 5 minutes après avoir éteindre la lampe. Ne pas ouvrir pendant 5 minutes après la coupure.
- Risk of exposure to excessive ultraviolet radiation. Do not operate without complete lamp enclosure in place or when lens is damaged. Risque d'exposition aux rayonnements ultraviolets excessifs. Ne pas faire fonctionner sans le boîtier complet de lampe mis en place ou lorsque l'objectif est endommagé.

Heat

When lamps are lit, the interior of the luminaires becomes very hot. To aid in the airflow circulation within the luminaires, after dousing the lamps, wait 5 minutes before removing power to the luminaires. This will provide enough time for the equipment fan to cool off the unit. Users should wait until the unit is cool to the touch before servicing or handling.

Note: Also, refer to “[Fixture Shutdown](#)” on page 44 for additional information.

Lamp Life

- When operating arc lamps, allow luminaires to operate for at least 3 minutes. It takes about 3 minutes for the fill components (mercury and halogen-metal compounds) in the lamp tubes to vaporize completely. If the lamps are switched off earlier than 3 minutes, the fill components are partially vaporized. The inadequately vaporized fill components and the electrode material (tungsten) are deposited in the areas of the lamp tubes that have remained cool. As a result, the lamp tubes blacken prematurely and reduce the service life of the lamps.

- If the luminaire will be dimmed out for more than two hours, the lamp should be doused.

Solid State Electronics



Electrostatic Discharge (ESD)

Electrostatic discharge (ESD) presents a significant danger to solid state electronic components (semiconductor devices and PC board assemblies). Static electricity can build on a variety of common objects (including people) simply by handling or moving. ESD rarely results in immediate failure of a component, but shows up later as an intermittent problem or severely reduces the life of the component. All VARI*LITE equipment uses solid state electronics and appropriate precautions to protect them should be observed when servicing.

Printed Circuit Boards (PCBs)

All PC boards should be shipped in electrostatic shielding bags. When handling PC boards or components, devices such as conductive mats and conductive wrist straps should be used whenever possible. If these precautionary devices are not available, handling of PC boards and components should be avoided.



CAUTION: Black foam (used to package solid state electronics) should never be used for packing batteries or put in contact with PC boards which contain batteries.

Troubleshooting

Error Messages

If a problem occurs during luminaire calibration, at the end of the calibration sequence the Menu Display will cycle through any applicable error message(s), one at a time until the end of the list is reached. To review the error messages again, it will be necessary to access them using the Status function. Also, the VL4000 BeamWash Luminaire stores error messages in a log file within the luminaire. The log file can be downloaded from the fixture's USB port as described in ["USB Logging" on page 76](#).

To access error messages:

- Step 1. Press [ESC].
- Step 2. Press [Up] / [Down] arrows until Fixture appears. Press [OK].
- Step 3. Press [Up]/ [Down] arrows to access Status. Press [OK]. (Display will now scroll through any error messages or display OK if no errors).

Table A-1: Error Messages

| Display | Meaning |
|--------------------------|--|
| OK | No Errors Found - All Sensors Responded Properly |
| Pan Sensor | Pan Sensor (Encoder) Error |
| Pan Encoder | Pan Encoder Error |
| Tilt Sensor | Tilt Sensor (Encoder) Error |
| Tilt Encoder | Tilt Encoder Error |
| Dimmer Sensor | Dimmer Sensor Error |
| Cyan Sensor | Cyan Color Sensor Error |
| Yellow Sensor | Yellow Color Sensor Error |
| Magenta Sensor | Magenta Color Sensor Error |
| CTO Sensor | CTO Sensor Error |
| Edge Sensor | Edge Sensor Error |
| Zoom Sensor | Zoom Sensor Error |
| Color Whl1 Sensor | Color Wheel 1 Sensor Error |
| Color Whl2 Sensor | Color Wheel 2 Sensor Error |
| Gobo Whl1 Sensor | Rotating Gobo Wheel 1 Sensor Error |
| Gobo 1 Index Sensor | Rotating Gobo Wheel 1 Indexing Sensor Error |
| Gobo Whl2 Sensor | Rotating Gobo Wheel 2 Sensor Error |
| Gobo 2 Index Sensor | Rotating Gobo Wheel 2 Indexing Sensor Error |
| Animation Whl Sensor | Animation Wheel Sensor Error |
| Animation Index Sensor | Animation Wheel Indexing Sensor Error |
| Iris Sensor | Iris Mechanism Sensor Error |
| Prism Sensor | Prism Mechanism Sensor Error |
| Prism Rotate Sensor | Prism Rotating Sensor Error |
| Beam Shape Sensor | Beam Shape Sensor Error |
| Beam Shape Rotate Sensor | Beam Shape Rotate Sensor Error |
| Wash Lens | Wash Lens Sensor Error |
| Strobe Sensor | Strobe Sensor Error |

Troubleshooting Guide

If a problem is suspected, first try recalibrating the luminaire to prompt an error message. The chart below provides possible causes and remedies for various error messages and/or symptoms.



CAUTION: Some troubleshooting is included for reference only. Performing remedies may void product warranty. Refer to the Vari-Lite Limited Warranty card included with the product.

Table A-2: Troubleshooting Guide

| Message | Symptom | Description | Possible Cause/Remedy |
|------------------|--|-------------------------------|---|
| Lamp Power Douse | Lamp does not strike upon start-up | Lamp Off option is configured | - Reconfigure lamp startup option in Lamp config menu. |
| n/a | Lamp douses frequently | Lamp Douse | Fan failure... - check head and enclosure fans for proper operation. Ballast overheating... - operating within the specified ambient temperature? - check enclosure vents for debris / dirt. - check fan settings in menu. - check enclosure fans for proper operation. NOTE: Upon initial power up, ballast fans will run for a few seconds and then operate as needed. Enclosure vents must be clear of debris and dirt to allow proper airflow. |
| n/a | Lamp will not strike | Lamp Strike Failure | Lamp cutout switch disengaged... - check lamp cutout switches at lamp box and fan ducts. Bad lamp... - replace lamp. Low input voltage... - check input power (must be 200 to 240 VAC). Fan failure... - check head and enclosure fans for proper operation. |
| n/a | Luminaire behaves oddly | DMX Map Not Matched | Console library not set correctly... - check console library matches DMX map of luminaire. |
| n/a | Luminaire does not power up | No power | Circuit not energized... - verify circuit breaker (at source) is turned on. Not plugged in... - ensure A/C cable is connected to power source. |
| n/a | Self tests will not run or software download does not work from luminaire. | DMX Data Input | Detecting DMX data... - disconnect DMX input cable. |
| n/a | No response to DMX data | DMX Failure | DMX connector disconnected... - check DMX DATA IN connection. |
| n/a | Erratic control of luminaire | DMX Termination | No DMX termination or termination not correct... - check for DMX terminator. - Luminaire DMX address does not match console patch. |

Routine Maintenance

Lamp Removal and Installation



WARNING: Disconnect fixture before relamping. Déconnectez le projecteur avant que le changement de lampe.



CAUTIONS & WARNINGS

- Wear cotton gloves or other covering while installing lamp. Touching lamp glass with bare fingers will leave oil and may cause the lamp to explode or reduce lamp life. If touched, use isopropyl alcohol and cotton cloth to thoroughly clean glass portion of lamp.
- Hot Lamp. Luminaire must remain powered on for 5 minutes after dousing lamp. Do not open for 5 minutes after switching off. Lampe chaude. Le luminaire doit rester en marche pendant 5 minutes après avoir éteindre la lampe. Ne pas ouvrir pendant 5 minutes après la coupure.
- Risk of exposure to excessive ultraviolet radiation. Do not operate without complete lamp enclosure in place or when lens is damaged. Risque d'exposition aux rayonnements ultraviolets excessifs. Ne pas faire fonctionner sans le boîtier complet de lampe mis en place ou lorsque l'objectif est endommagé.

To replace lamp:

- Step 1. Ensure power is completely removed from luminaire.
- Step 2. Set the luminaire head horizontally.
- Step 3. Engage tilt lock to secure luminaire head in position.
- Step 4. At back of luminaire, using #2 Phillips screwdriver, remove lamp socket cover by loosening the two quarter-turn captive screws. Note: lamp socket cover is connected with a safety tether.

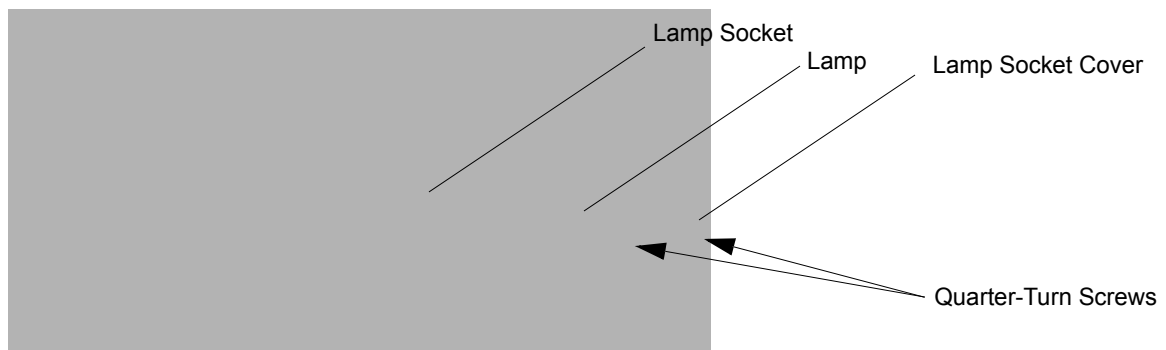

Figure A-1: Lamp Socket Cover Removal

- Step 5. To remove lamp, grasp lamp base by hand, twist lamp counter-clockwise until lamp's tabs align with slots in lamp socket (see [Figure A-2](#) on [page 85](#) for more information), and remove lamp by pulling it straight out of socket.

- Step 6. Remove replacement lamp from shipping box.
 Step 7. As shown in [Figure A-2](#), align replacement lamp tabs with lamp socket.

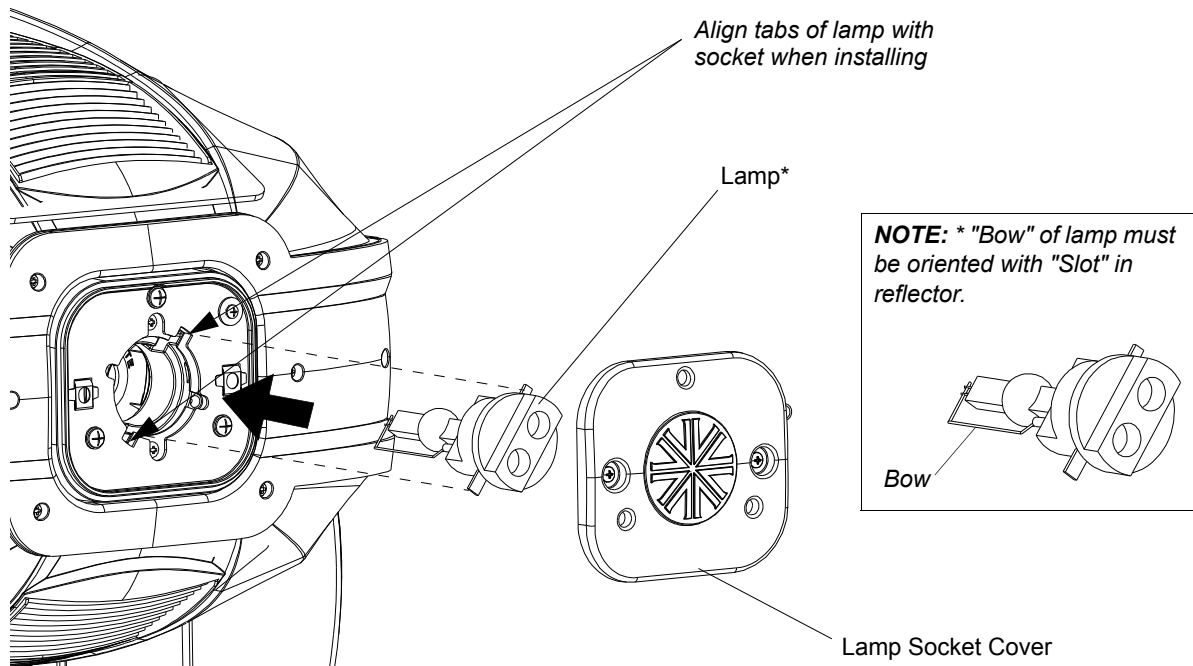

Figure A-2: Lamp Installation

- Step 8. Install lamp fully into lamp socket, taking care not to touch lamp glass.
 Step 9. Turn lamp clockwise to seat lamp into socket. Lamp base should be aligned as illustrated in [Figure A-3](#).

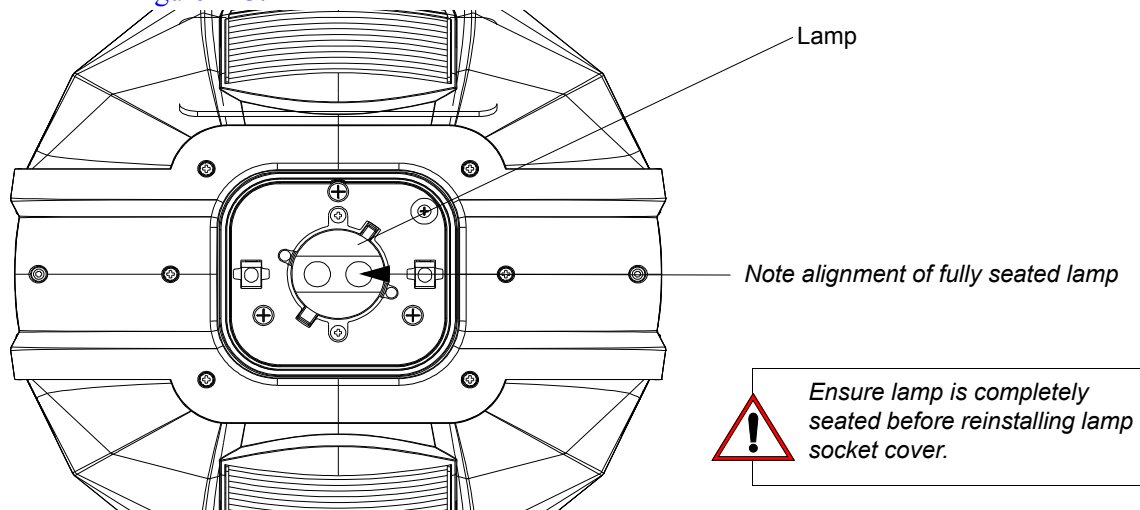

Figure A-3: Installed Lamp

- Step 10. Reinstall lamp socket cover. Make sure safety tether is completely encapsulated within lamp socket cover.
 Step 11. Disengage tilt lock to allow luminaire head to move freely.
 Step 12. Align lamp as described in ["Align Lamp For Maximum Beam Irradiance"](#) on page 19.

Fixed Color Wheel Filter Removal and Installation

To remove and replace fixed color filters:

Step 1. Before removing power from luminaire, move Edge towards front of luminaire with control console or via luminaire menu system.



WARNING: Remove power from luminaire and allow luminaire to cool completely before performing this procedure.

Step 2. Remove power from luminaire and allow luminaire to cool completely.

- Step 3. Depending on which color filter wheel you need to access, do the following:
- For Fixed Color Wheel 1 (closest to the rear of luminaire), remove head cover assembly as indicated in [Figure A-4](#) by loosening four captive screws and lifting cover away from luminaire head. Note, head cover is attached by a safety tether.
 - For Fixed Color Wheel 2 (closest to the front of luminaire), remove head cover assembly as indicated in [Figure A-4](#) by loosening our captive screws and lifting cover away from luminaire head. Note, head cover is attached by a safety tether.

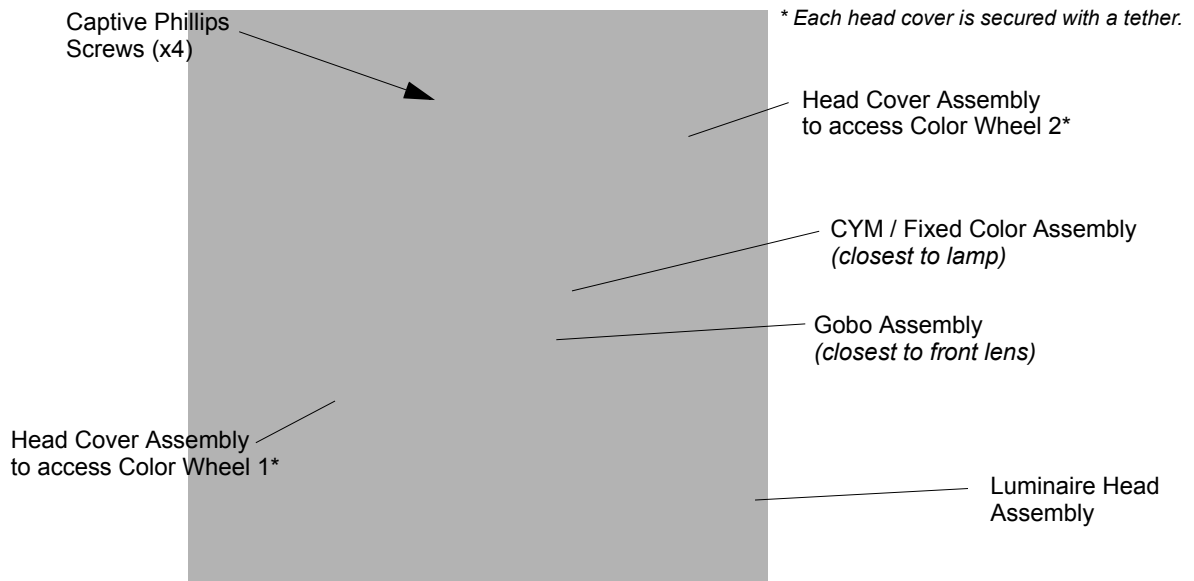

Figure A-4: Replacing Fixed Color Filters



CAUTION: Wear protective gloves or other protective covering while handling filters to avoid leaving fingerprints. Filters are extremely fragile and can break if not handled carefully. If dirty, clean with isopropyl alcohol and a soft, lint-free cloth.

Note: For standard fixed color filters, refer to [“Fixed Color Wheel 1” on page 30](#) or [“Fixed Color Wheel 2” on page 31](#)

- Step 4. At fixed color wheel, slowly rotate wheel by hand until filter to be removed is visible on assembly as shown in [Figure A-5](#).
- Step 5. At filter to be removed, (1) press filter out of fixed color wheel with fingers and (2) guide filter up and away from fixed color wheel.

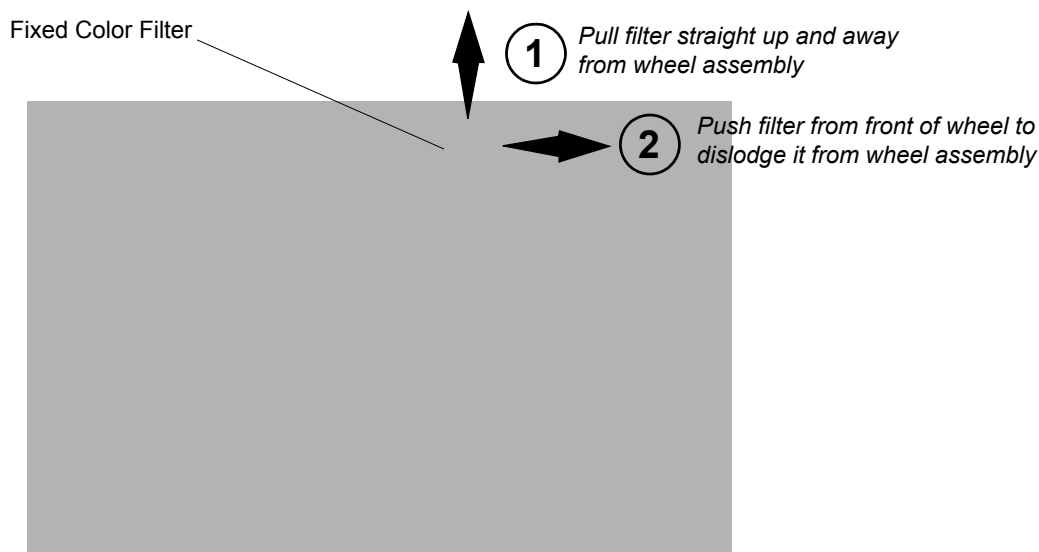

Figure A-5: Removing Fixed Color Filters

- Step 6. Install replacement filter into slot. Note orientation of fixed color filter as indicated in [Figure A-6](#). Make sure filter is inserted and secured by fixed color wheel retaining clip as shown in [Figure A-6](#).

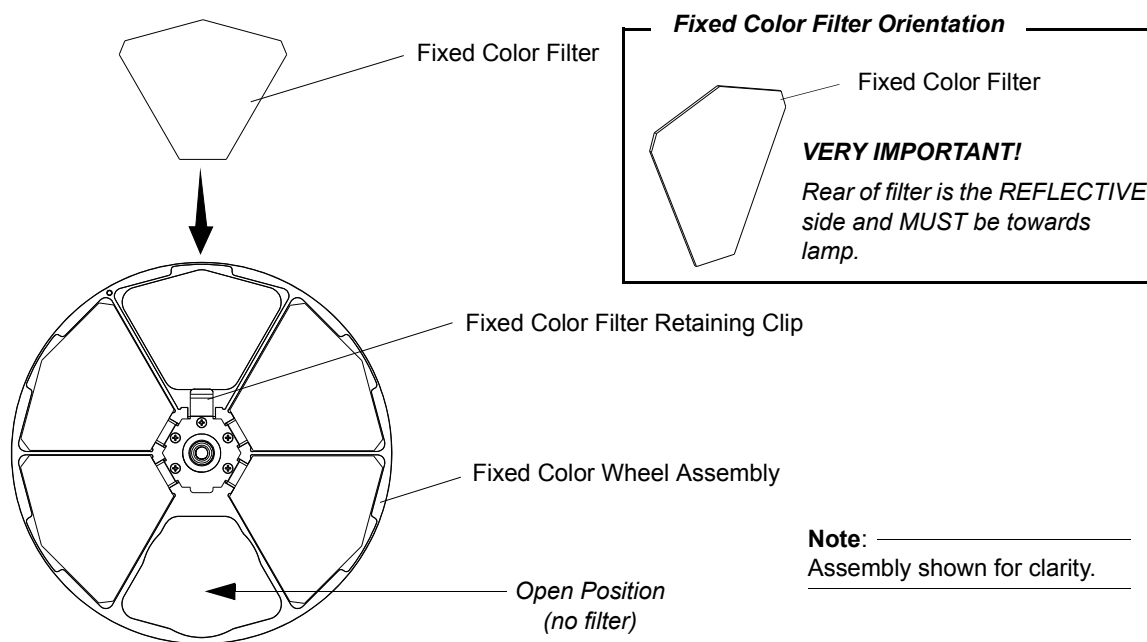

Figure A-6: Installing Fixed Color Filters

- Step 7. After filter is installed, reinstall head cover(s).

Rotating Gobo Removal and Installation



CAUTION: VL4000 BeamWash Luminaires accept glass gobos only. Use of metal gobos in these luminaires may damage gobo assembly and will void the luminaire warranty.

To remove and replace rotating gobos:

Step 1. Before removing power from luminaire, move Edge towards front of luminaire with control console or via luminaire menu system.



WARNING: Remove power from luminaire and allow luminaire to cool completely before performing this procedure.

Step 2. Remove power from luminaire and allow luminaire to cool completely.

- Step 3. Depending on which rotating gobo wheel you need to access, do the following:
- For Rotating Gobo Wheel 1 (closest to the rear of luminaire), remove head cover assembly as indicated in [Figure A-4](#) by loosening our captive screws and lifting cover away from luminaire head. Note, head cover is attached by a safety tether.
 - For Rotating Gobo Wheel 2 (closest to the front of luminaire), remove head cover assembly as indicated in [Figure A-4](#) by loosening our captive screws and lifting cover away from luminaire head. Note, head cover is attached by a safety tether.

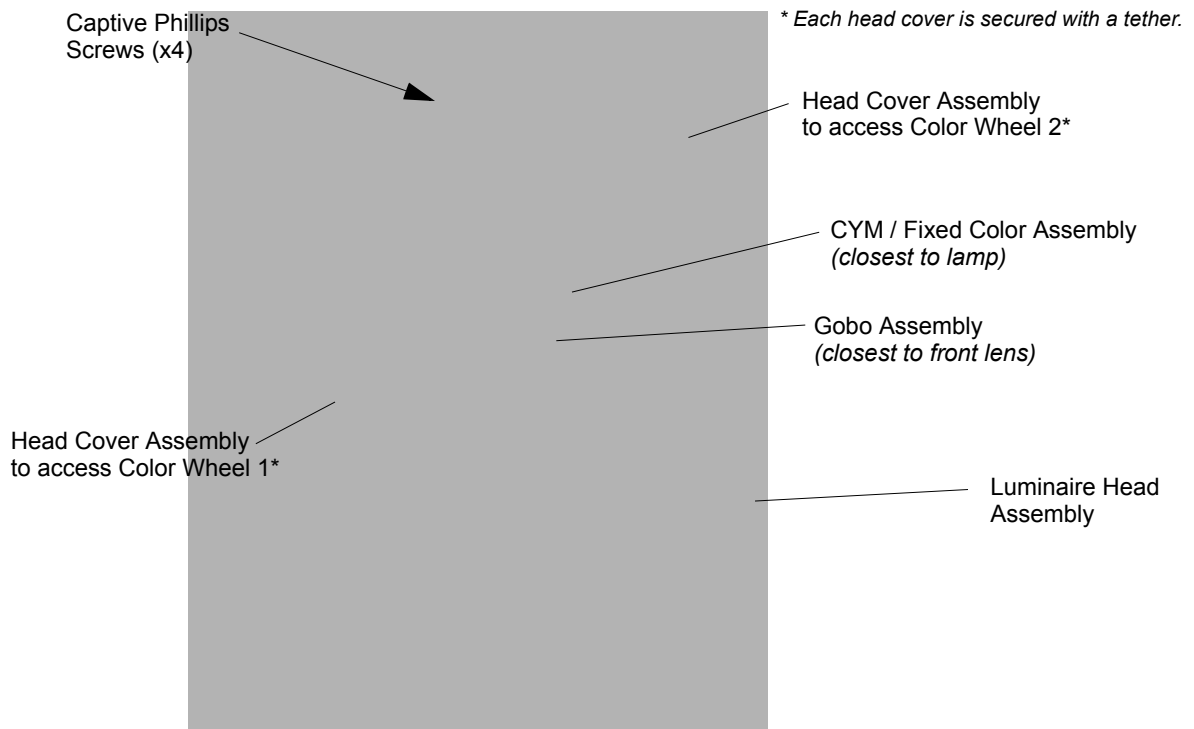

Figure A-7: Replacing Rotating Gobos



CAUTION: Wear protective gloves or other protective covering while handling gobos to avoid leaving fingerprints. If dirty, clean with isopropyl alcohol and a soft, lint-free cloth.

Note: For the standard load of rotating gobos, refer to “Rotating Gobo Wheel 1” on page 32 or “Rotating Gobo Wheel 2” on page 33

- Step 4. At rotating gobo wheel, slowly rotate wheel by hand until gobo to be removed is visible on assembly.
- Step 5. Grip gobo assembly and pull up to remove from luminaire head.
- Step 6. **Before installing gobo assembly into rotating gobo wheel assembly**, make note of relationship between carrier and main gear slot as illustrated in Figure A-8.
- Align gobo assembly gear timing marks **WITH**...
 - Slot in main gear on gobo wheel assembly. You may have to rotating gear by hand for alignment.

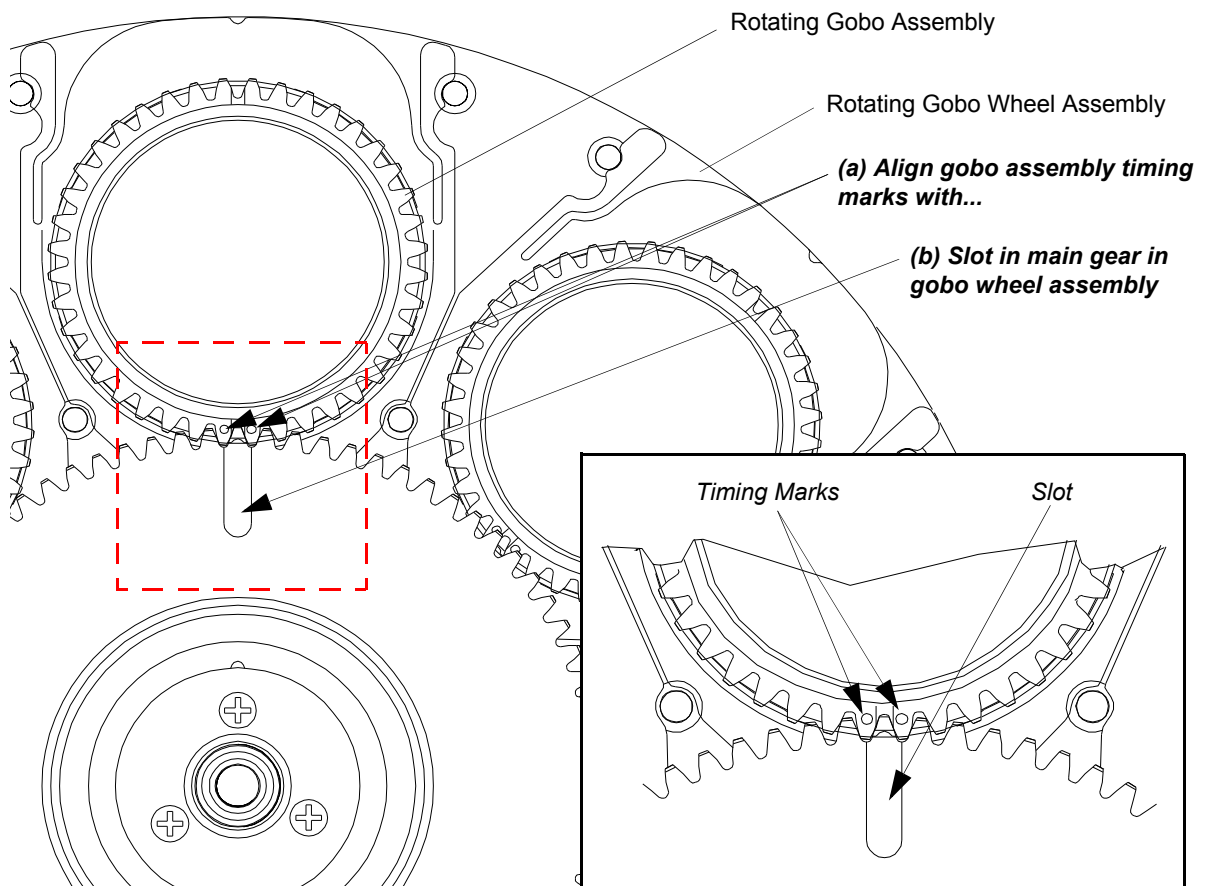

Figure A-8: Rotating Gobo Wheel - Gobo Clocking

- Continued Next Page -

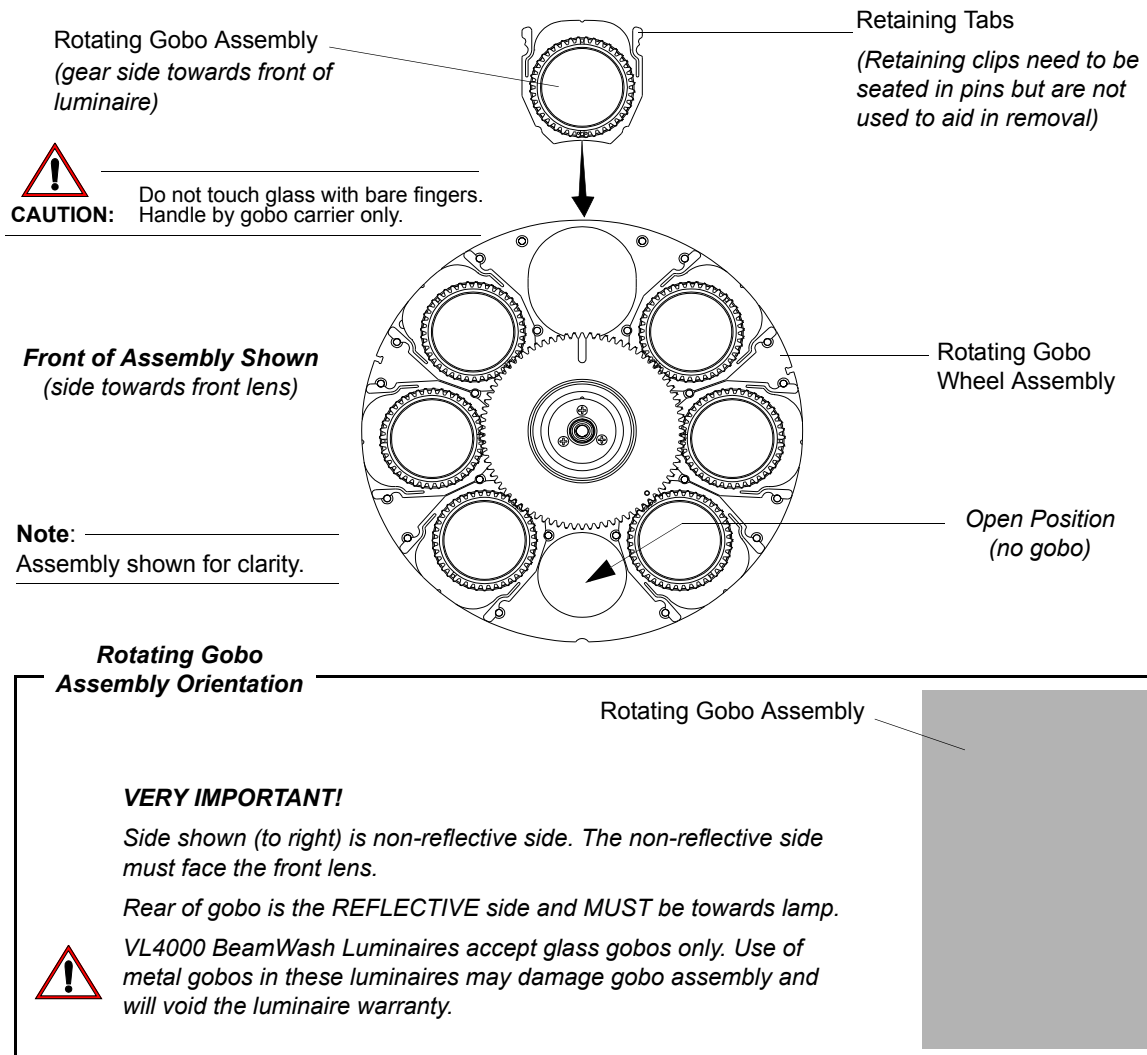

Figure A-9: Rotating Gobo Wheel - Gobo Installation

- Step 7. After ensuring main gear slot and gobo assembly timing marks are properly aligned (as described in Step 7, install replacement rotating gobo assembly into gobo position. Note orientation of rotating gobo assembly as indicated in [Figure A-9](#).
- Step 8. After rotating gobo assembly is installed, reinstall head cover(s).

Animation Wheel Removal and Installation

To remove and replace animation wheel:

Step 1. Before removing power from luminaire, move Edge towards front of luminaire with control console or via luminaire menu system.



WARNING: Remove power from luminaire and allow luminaire to cool completely before performing this procedure.

Step 2. Remove power from luminaire and allow luminaire to cool completely.

Step 3. Remove head cover assembly as indicated in [Figure A-10](#) by loosening four captive screws and lifting cover away from luminaire head. Note, head cover is attached by a safety tether.

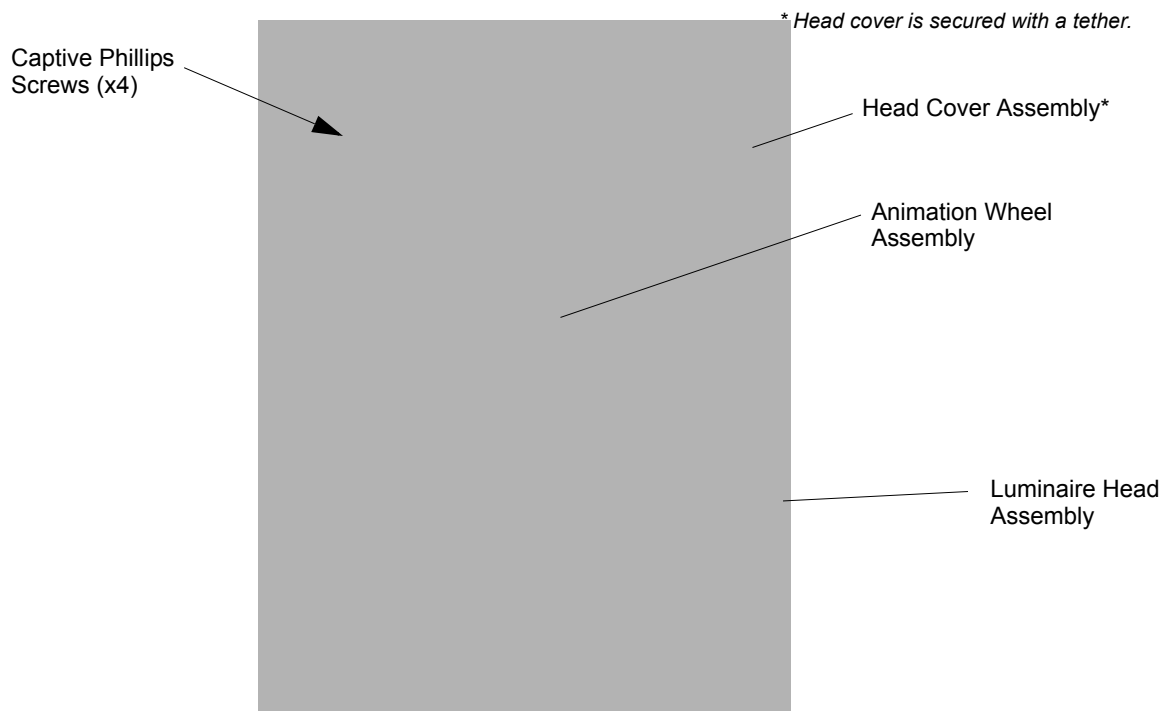

Figure A-10: Replacing Animation Wheel



CAUTION: Wear protective gloves or other protective covering while handling the animation wheel to avoid leaving fingerprints. If dirty, clean with isopropyl alcohol and a soft, lint-free cloth.

Note: For the standard load of the animation wheel, refer to [“Animation Wheel - Concurrent” on page 34](#) or [“DMX Operation” on page 35](#).

Step 4. Loosen screw on bulkhead so animation arm can swing out

Step 5. Remove one screw from animation frame.

CAUTION: Be careful not to lose belt bearing, washer, screw or post. These will be required for reassembly and installation.

Step 6. Slip belt off of animation wheel. Remove wheel.

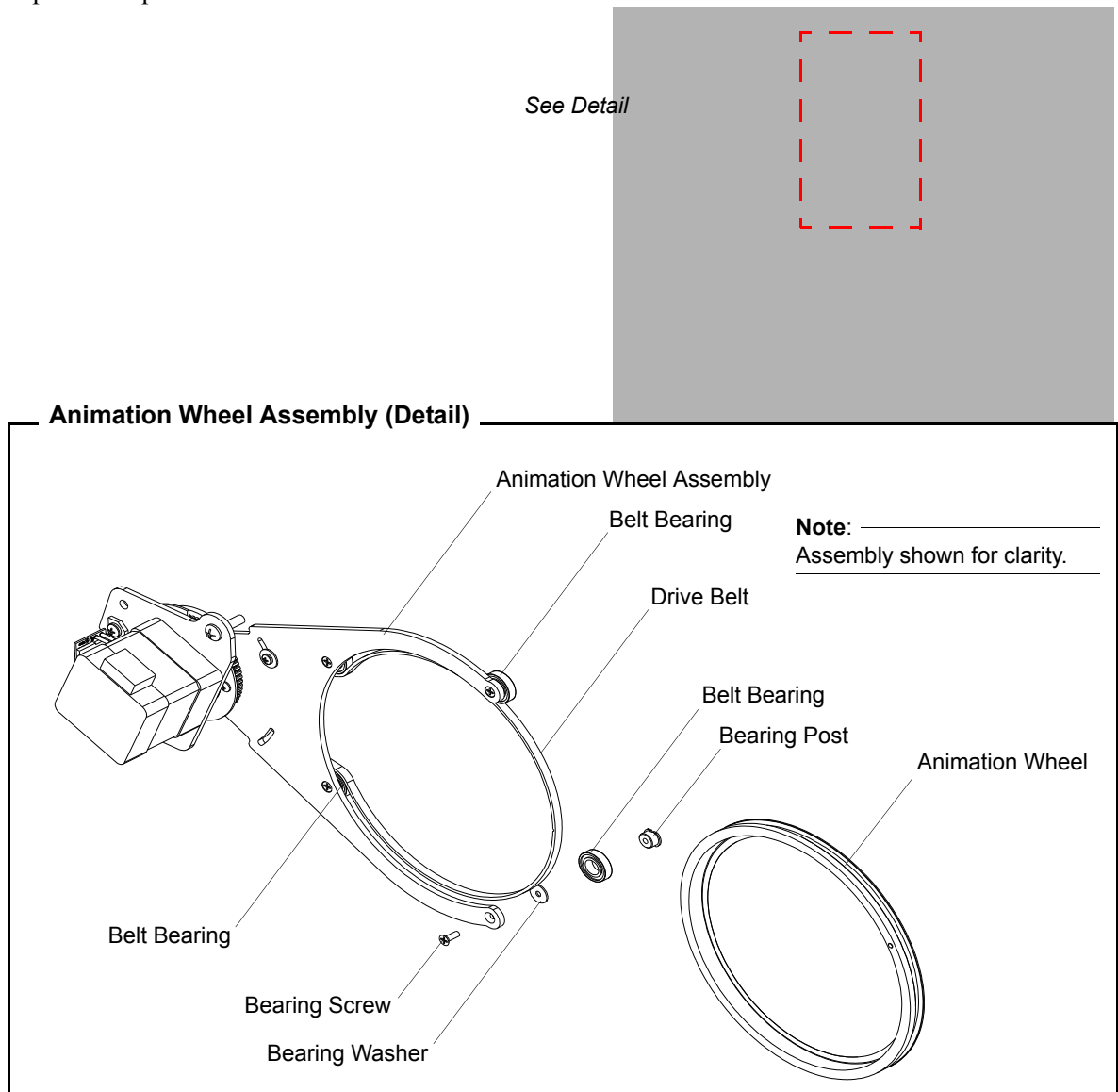

Figure A-11: Animation Wheel Removal & Installation

- Step 7. Slip belt around new wheel. Seat on all three bearings.
- Step 8. Reassemble post onto bearing and washer. Hand-tighten down with screw.
- Step 9. Swing animation arm back into beam area and hand-tighten down bulkhead screw.
- Step 10. After animation wheel is installed, reinstall head cover.

Prism Removal and Installation

To remove and replace prism:

Step 1. Before removing power from luminaire, move Edge towards front of luminaire with control console or via luminaire menu system.



WARNING: Remove power from luminaire and allow luminaire to cool completely before performing this procedure.

Step 2. Remove power from luminaire and allow luminaire to cool completely.

Step 3. Remove head cover assembly as indicated in [Figure A-12](#) by loosening four captive screws and lifting cover away from luminaire head. Note, head cover is attached by a safety tether.

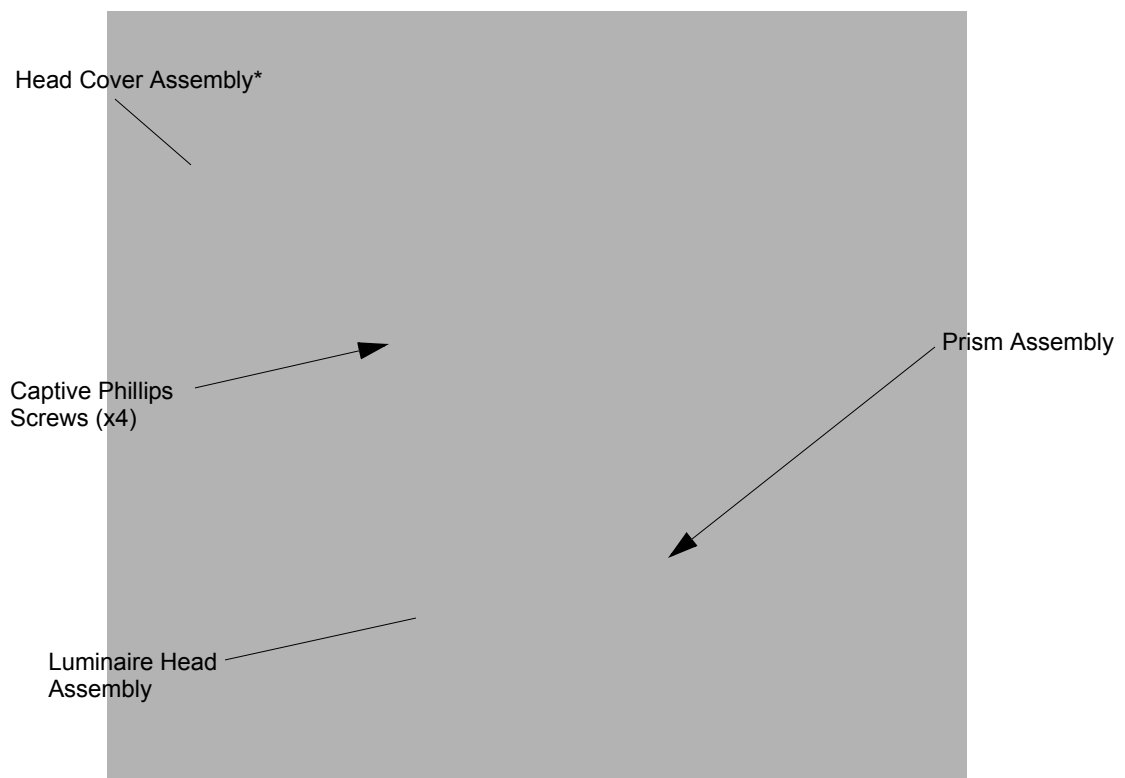

* Head cover is secured with a tether.

Figure A-12: Replacing Prism



CAUTION: Wear protective gloves or other protective covering while handling prism to avoid leaving fingerprints. If dirty, clean with isopropyl alcohol and a soft, lint-free cloth.

Step 4. De-tension belt by loosening 1/4" hex standoffs on top of sensor.

Step 5. Slide belt off of prism assembly.

- Step 6. As indicated in [Figure A-13](#) remove two screws securing prism to arm. **IMPORTANT!** Be careful not to lose removed screws. These will be required for reassembly and installation.
- Step 7. Install new prism using screws removed in previous step.
- Step 8. Install belt around prism assembly.
- Step 9. Slide roller back into place so belt is tensioned. **IMPORTANT!** Do not over-tension or prism will stall during rotation.
- Step 10. Hand tighten hex standoffs.

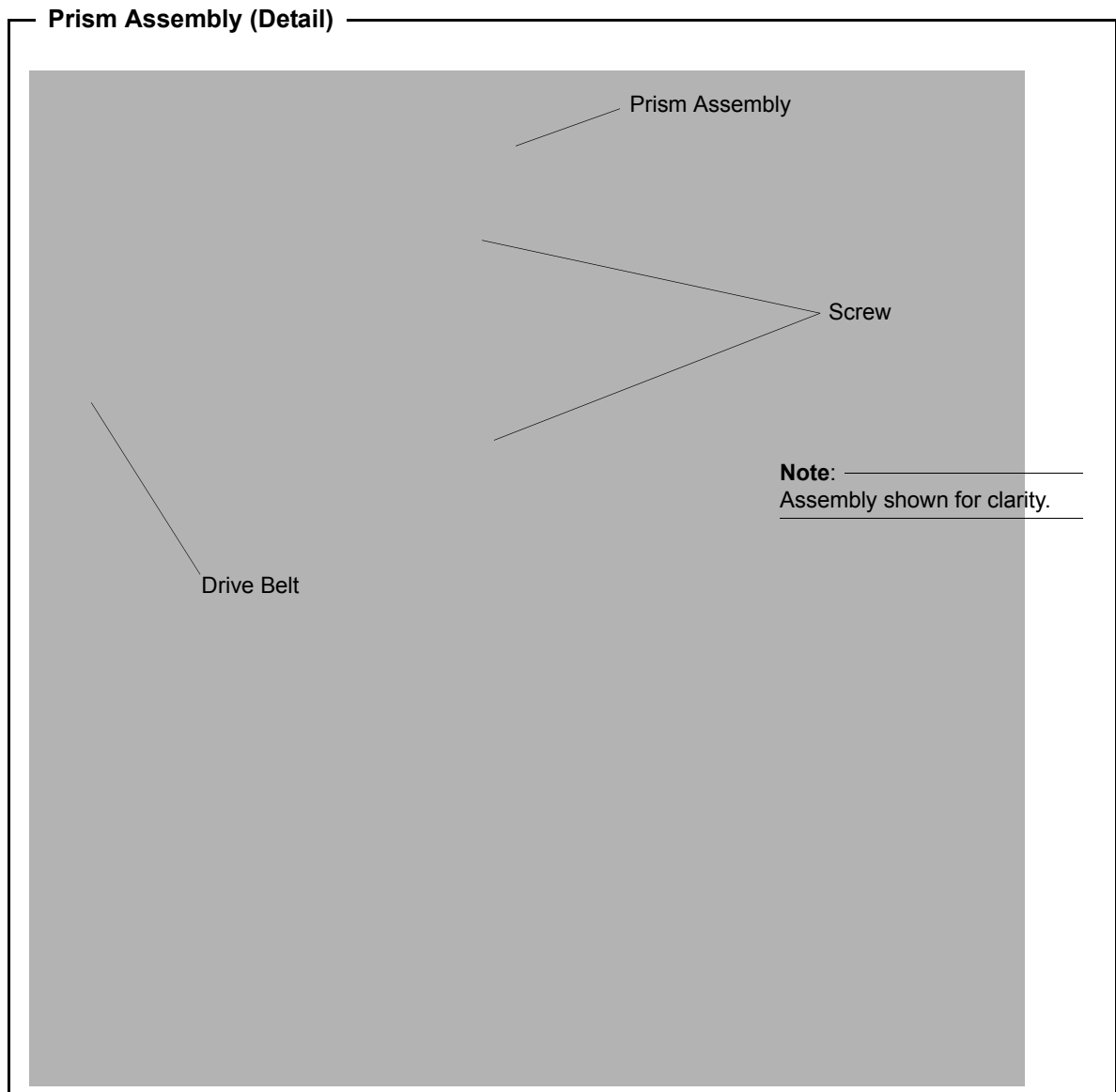

Figure A-13: Prism Assembly Detail

- Step 11. Reinstall head cover.

Cleaning Optical Lenses and Filters



WARNING: Remove power from luminaire before performing maintenance.



WARNING: Acetone is a harsh cleaning agent and solvent. Acetone is very flammable. Please handle acetone according to manufacturer's safety instructions and precautions.

The front lens, optics/color filters, and reflector may require cleaning after extended use.

- **FRONT LENS:** Use a isopropyl alcohol with a soft, lint-free cloth to clean the front lens.
- **OPTICS/COLOR FILTERS/ GOBOS/ANIMATION WHEELS:** Use Acetone or Isopropyl Alcohol along with a soft, lint-free cloth to clean the optics/color filters.
- **REFLECTOR:** Use Acetone or Isopropyl Alcohol along with a soft, lint-free cloth to clean the reflector.



CAUTION: Do not continuously rub color filters or reflector - it may damage or remove the optical coating.

Notes

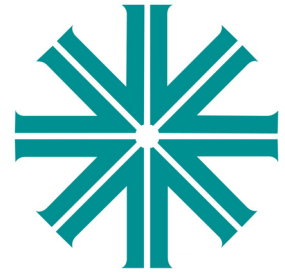

APPENDIX B.

Technical Specifications

Note: Vari-Lite reserves the right to change details of design, materials and finishes. Specifications are subject to change without notice. Some features may be the result of future software updates. VARI*LITE automated lighting equipment is made in the U.S.A.

Mechanical

Color System

A three filter CYM cross fading system capable of extremely smooth movements at both slow and fast speeds, and a variable CTO color temperature correction system.

Fixed Color Wheels

Two opposing fixed color wheels each with five interchangeable color filters are capable of producing multi-color effects and variable wheel rotations.

Intensity Control

Full field dimming designed for smooth timed fades as well as quick dimming effects.

Strobe

High-performance dual blade strobe system capable of ultra-fast operation.

Pan and Tilt

Smooth, time-controlled continuous motion by way of three-phase stepper motor systems.

- Range: Pan - 540°, Tilt - 270°.
- Accuracy: 0.3° resolution.

Weights

Unit weighs (luminaire only, without accessories) 101 lbs (45.8 kg).

Spacing

Unit hangs on 30 inch (762 mm) centers.



Figure B-1: Luminaire Hanging & Spacing Requirements

Optical

Wash Mode

- **Wash Zoom Optics:** A 6-element 6:1 zoom optics system, covering a range from 10° to 60°.
- **Beam Shaping:** Unique indexing and rotating beam shaping alters output from round to elliptical with minimal light loss.
- **Edge and Hot Control:** Variable hot / edge adjustment provides a multitude of different wash styles.

Beam Mode

- **Beam Zoom Optics:** A 6-element 10:1 zoom optics system, covering a range from 4° to 40°.
- **Beam Size Control:** A mechanical iris provides continuous beam size control for rapid and smooth timed beam angle changes. Near zero degree beam angle is possible with nearly fully closed iris.
- **Rotating Gobo Wheels:** Two gobo wheels combine to each offer seven rotatable, indexable gobo positions and one open position.



Note: VL4000 BeamWash Luminaires accept glass gobos only. Use of metal gobos in these luminaires may damage gobo assembly and will void the luminaire warranty.

- **Animation Wheel:** A dynamic animation wheel offers unique rotatable, indexable patterns with variable motion control from horizontal to vertical.
- **Rotating Prism:** Independent rotating and indexing 5-facet step prism.
- **Lenticular Effect:** Unique indexing and rotating lenticular effect alters output from round to rectangular and to create extruded gobo imagery.
- **Edge and Pattern Focus:** Variable beam focus to soften edges of gobos or s. Remarkable depth of field capability allows morphing effects between gobos and the animation wheel.

Shaft Mode

- **Shaft Optics:** 4° adjustable to near 0° with iris.
- **Beam Size Control:** A mechanical iris provides continuous beam size control for rapid and smooth timed beam angle changes.
- **Rotating Gobo Wheels:** Two gobo wheels combine to each offer seven rotatable, indexable gobo positions and one open position.
- **Animation Wheel:** A dynamic animation wheel offers unique rotatable, indexable patterns with variable motion control from horizontal to vertical.
- **Rotating Prism:** Independent rotating and indexing 5-facet step prism.
- **Lenticular Effect:** Unique indexing and rotating lenticular effect alters output from round to rectangular and to create extruded gobo imagery.

Edge and Pattern Focus

Variable beam focus to soften edges of gobos or s. Remarkable depth of field capability allows morphing effects between gobos and the animation wheel.

Source

1200W Philips MSR Gold FastFit lamp (rated for 800-1400W operation) running at 1400W in Standard mode or 1200W in Studio mode.

Reflector

Precision faceted, elliptical glass reflector system with dichroic cold mirror coating.

Color Temperature

6000K

Fixture Output

- Standard Mode: 43,000 lumens
- Studio Mode: 35,000 lumens

Intensity Control

Full field dimming designed for smooth timed fades as well as quick dimming effects. It also features a high-performance dual blade strobe system capable of ultra-fast operation.

Operational

Power Requirements

Standard AC power distribution from 200 - 240VAC, 50/60 Hz. The unit requires up to 11.0A depending on the AC supply voltage.*

Note: *For a breakdown of total luminaire current draw at different voltages, see [“Current vs. Voltage” on page 14.](#)

Operational Temperature

- Standard Mode: -20° to 104°F (-29° to 40°C)
- Studio Mode: -20° to 122°F (-29° to 50°C)

Cooling

Forced-air cooling.

Control

Control by DMX512 protocol. Compatible with a wide variety of DMX512 consoles.

DMX Channels

- 46 Channels (Enhanced 16-Bit Mode)
 - 41 Channels (16-Bit Mode).
-

Note: For complete information, refer to, [“VL4000 BeamWash Channel Mapping” on page 35.](#)

RDM Control

Completely compatible with a wide variety of RDM devices. For RDM implementation see, [“VL4000 BeamWash Luminaire RDM Parameter IDs” on page 53.](#)

Menu System

Full color LCD with battery powered control.

Mounting Position

The luminaire can be mounted and operated in any orientation. For spacing requirements, refer to [Figure B-1 on page 98.](#)

